



Series 965

User's Manual



CE 96

**1/16 DIN
Microprocessor-Based
Auto-tuning Control**

**TOTAL
CUSTOMER
SATISFACTION**
3 Year Warranty

ISO 9001



Registered Company
Winona, Minnesota USA



Watlow Controls, 1241 Bundy Blvd., P.O. Box 5580, Winona, MN 55987-5580, Phone: 507/454-5300, Fax: 507/452-4507

0600-0003-0000 Rev. C
July 1998
Supersedes: 0600-0003-0000 Rev. B

\$10.00
Made in the U.S.A.

 Printed on Recycled Paper

About This Manual

How to Use this Manual

We have designed this user's manual to be a helpful guide to your new Series 965. The headlines in the upper right and left corners indicate which tasks are explained on that page.

Notes and Safety Information

NOTE:

Details of a "Note" appear here, in the narrow box on the outside of each page.



CAUTION:

Details of a "Caution" appear here, in the narrow box on the outside of each page.



WARNING:

Details of a "Warning" appear here, in the narrow box on the outside of each page.

We use notes, cautions and warnings throughout this book to draw your attention to important information.

Notes are printed in bold in the margin to alert you to an important detail.



A Caution symbol (an exclamation point in a triangle) appears with information that is important to protect equipment and performance. Read and follow all cautions that apply to your application.



A Warning symbol (a lightning bolt in a diamond) appears with information that is important to protect people and equipment from damage. Pay very close attention to all warnings that apply to your application.

Technical Assistance

If you encounter a problem with your Watlow controller, review all of your configuration information for each step of the setup, to verify that your selections are consistent with your applications.

If the problem persists after checking all the steps, call for technical assistance: Watlow Controls at (507) 454-5300, between 7:00 a.m. and 5:30 p.m. Central Standard Time. Ask for an applications engineer. When you call, have the following information ready:

- the controller's model number (the 12-digit number is printed on the top of the stickers on each side of the controller's case and on the top or right side of the circuit board);
- this user's manual;
- all configuration information;
- the Diagnostics Menu readings.

Warranty and Returns

For information about the warranty covering the Series 965, see page 37.

Comments and Suggestions

We welcome your comments and opinions about this user's manual and the Series 965. Send them to the Technical Editor, Watlow Controls, 1241 Bundy Blvd., P.O. Box 5580, Winona, MN 55987-5580. Or call (507) 454-5300. Or fax them to (507) 452-4507. (1459).

Page	Item
Chapter 1	
4	Starting Out With The Watlow Series 965
4	General Description
Chapter 2	
5	Install And Wire The Series 965
5	Panel Cutout
5	Dimensions
5	Installation Procedure
7	Wiring the Series 965
8	Sensor Installation Guidelines
8	Input Wiring
10	Output 1 Wiring
11	Alarm Wiring
12	System Wiring Example
Chapter 3	
13	How To Use The Keys And Displays
13	Keys, Displays & LEDs
Chapter 4	
14	How To Set Up The Series 965
14	Setting the Input Type DIP Switch
15	Entering Setup Menu
16	Setup Parameters
18	Setup Menu Table
19	Operation Parameters
20	Operation Menu Table
Chapter 5	
21	How To Tune And Operate
21	Auto-tuning
22	Manual Tuning
23	Manual and Automatic Operation
24	Using Alarms
25	Error Code Messages
Appendix 1	
27	Noise Sources
27	Decreasing Noise Sensitivity
28	Eliminating Noise
Appendix 2	
29	Entering the Calibration Menu
30	Restoring Factory Calibration
30	Calibration Menu

31	Calibration Procedures
34	Glossary
36	Index
37	Warranty and Returns
38	Specifications
39	Model Number Information
40	Declaration of Conformity
41	Quick Reference

Figures & Tables

Page	Figure	Item
4	Series 965 Input & Output Overview	1
5	Multiple Panel Cutout Dimensions	2
5	Series 965 Dimensions	3
6	Mounting, Case Side View & Collar	4
6	Case, Rear View & NEMA 4X Seal Example	5
7	High Voltage Power Wiring	6
7	Low Voltage Power Wiring	7
8	Thermocouple Sensor Input Wiring	8
8	0-5V $\overline{\text{dc}}$ Process Sensor Input Wiring	9
9	2- or 3-wire RTD Sensor Input Wiring	10
9	4-20mA Process Sensor Input Wiring	11
10	Switched DC Output Wiring	12
10	5A Mechanical Relay Wiring	13
10	4-20mA Process Wiring	14
10	0.5A Solid-state Relay w/o Suppression Wiring	15
11	Switched DC Output Wiring	16
11	5A Mechanical Relay Wiring	17
11	0.5A Solid-state Relay w/o Suppression Wiring	18
12	System Wiring Example	19
13	Series 965 Keys and Displays	20
14	DIP Switch Location & Orientation	21
15	Entering the Setup Menu	22
15	The Setup Menu	23
19	The Operation Menu	24
21	Auto-tuning at a 200°F Set Point	25
24	Alarm Display Examples	26
29	Entering the Calibration Menu	27
30	Calibration Menu	28

Tables

18	Input Ranges 1	
18	Setup Menu Prompts/Description	2
20	Operation Menu Prompts/Description	3
41	Quick Reference Sheet (Perforated)	

Chapter 1

Starting Out With The Watlow Series 965, A Microprocessor-Based Control

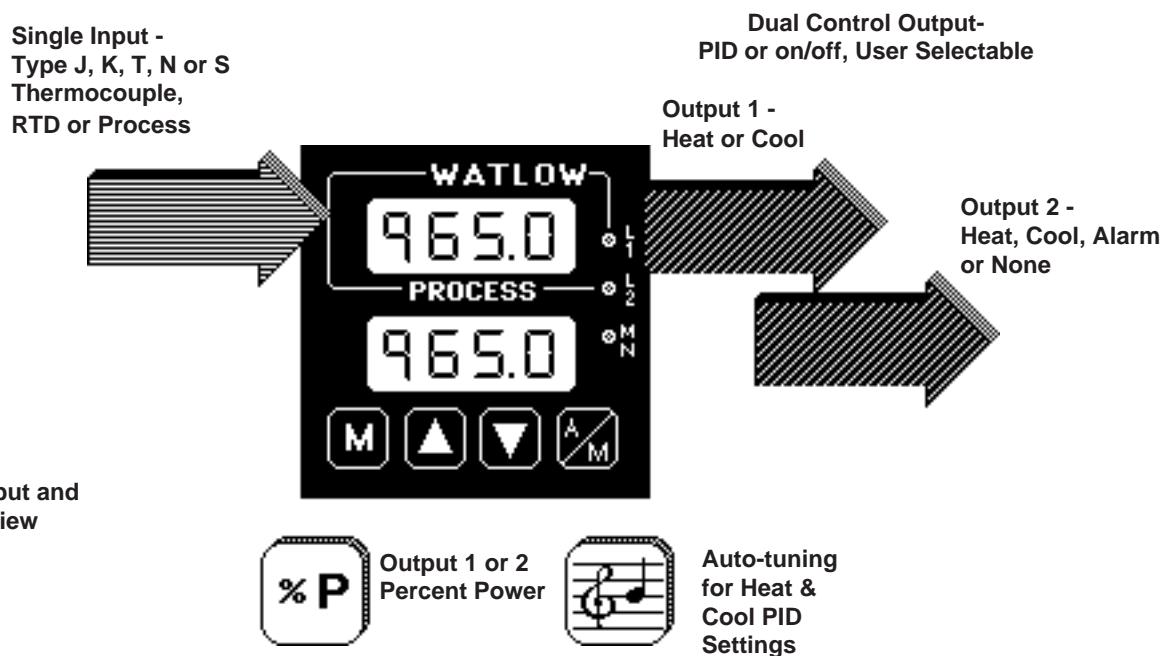

Figure 1 -
Series 965 Input and
Output Overview

General Description

Welcome to the Watlow Series 965, a 1/16 DIN microprocessor-based temperature control. The 965 has a single input which accepts type J, K, T, N or S thermocouple, RTD or process input.

With dual output, the primary can be heating or cooling while the secondary can be a control output opposite the primary output (heat or cool), alarm or none. Both outputs can be selected as either PID or on/off. PID settings include proportional band, reset/integral, and rate/derivative. Setting the proportional band to zero makes the Series 965 a simple on/off control with switching differential selectable under the HSC parameter.

Special 965 features include the NEMA 4X rating, dual four digit displays in either red or green, optional low volt power supply, auto-tuning for both heat and cool outputs, ramp to set point for gradual warm-up of your thermal system, and automatic/manual capability with bumpless transfer.

Operator-friendly features include automatic LED indicators to aid in monitoring and setup, as well as a calibration offset at the front panel. The Watlow Series 965 automatically stores all information in a non-volatile memory.

Install and Wire the Series 965

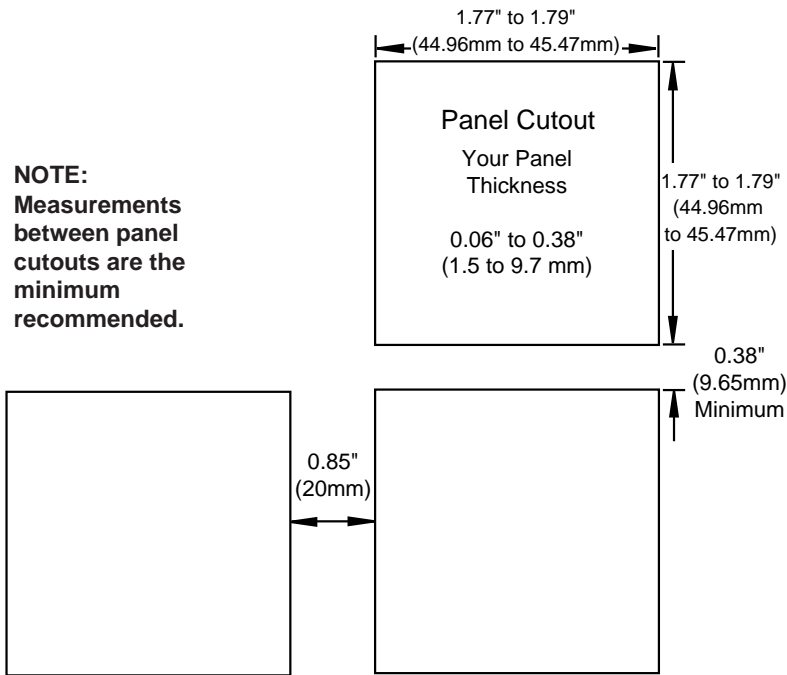

Figure 2 - Series 965 Multiple Panel Cutout Dimensions

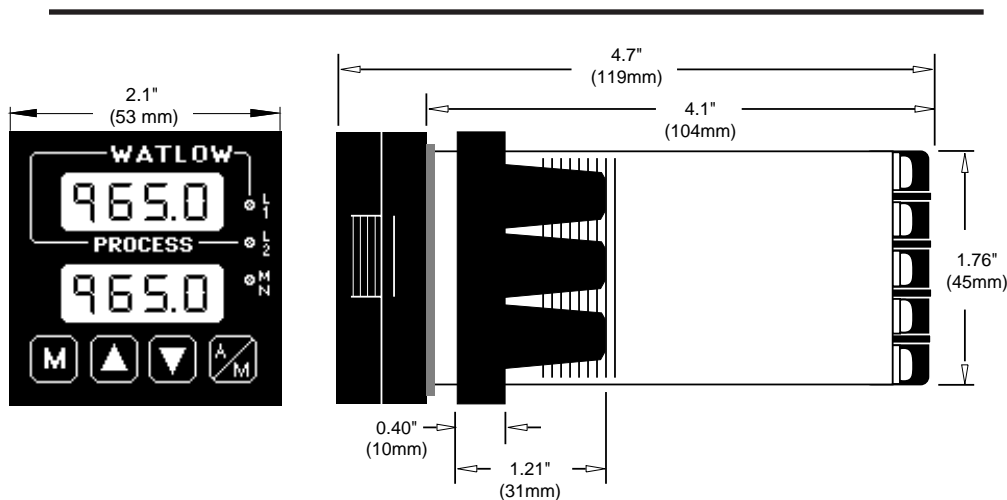

Figure 3 - Series 965 Dimensions

NOTE: For rapid mounting, use Greenlee punch #60020 and die #60021, or hand hydraulic unit, Kit #7306. All available from Grainger.

Installation Procedure

Follow this procedure to mount the Watlow Series 965 temperature control:

1. Make a panel cutout per the dimensions in Figure 2.
2. Remove the 965 chassis from its case. Holding each side of the bezel, press in firmly on the side grips until the tabs release. Pull the chassis out of the case and set aside for later installation.
3. Make sure the rounded side of the external case gasket is **facing** the panel surface. Check to see that the gasket is not twisted, and is seated within the case bezel flush with the panel. Place the case in the cutout you just made. Make sure the gasket is between the panel cutout and the case bezel. See Figure 4A.

Installation

Figure 4 -
Mounting, Case Side
View & Collar Cross
Section

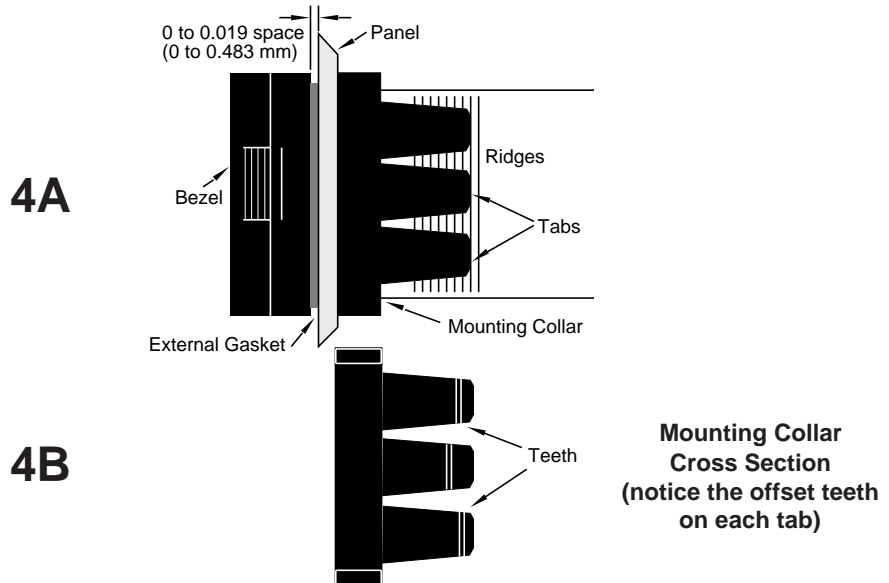

4. While pressing the front of the case firmly against the panel, slide the mounting collar over the back of the control. The tabs on the collar must line up with the mounting ridges on the case for secure installation. See Figure 4A again. Slide the collar firmly against the back of the panel getting it as tight as possible. Make sure you cannot move the case within the cutout; if you can you do not have a NEMA 4X seal.

NOTE:

To guarantee a proper NEMA 4X seal, make sure the gasket between the panel and the rim of the case is not twisted and is seated properly. **PRESS FIRMLY.**

Now let's make sure we have a tight seal. Use your thumb to lock the tabs into place while pressing the case from side to side. Don't be afraid to apply enough pressure to install the control. The tabs on each side of the collar have teeth which latch into the ridges. See Figure 4B. Each tooth is staggered at a different height, so only one of the tabs on each side are ever locked into the ridges at any time.

Looking at Figure 5, you see that the tabs on one side of the collar correspond with those on the opposite side. Make sure that the two corresponding tabs are the only ones locked in the ridges at the same time. If the matching tabs are not holding the case at the same time you **will not** have a NEMA 4X seal. You can make a visual check, or use your finger nail to pull out on each tab. **Only one on each side is engaged, and they must be corresponding as in Figure 5.** The space between the bezel and panel must be between 0 and 0.019" (0.48 mm).

Make sure that the two corresponding tabs below are locked in the ridges at the same time.

Figure 5 -
Case Rear View and
NEMA 4X Seal
Example

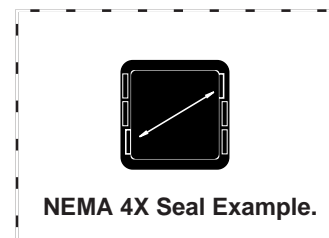
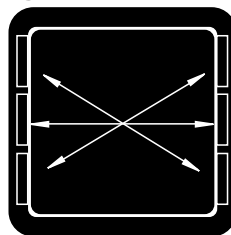

When removing the mounting collar, we suggest sliding a thin tool such as a putty knife or screwdriver under all three tabs on each side at once and pulling it back off the case.

5. Insert the control chassis into its case and press the bezel to seat it. Make sure the inside gasket is also seated properly and not twisted. The hardware installation is complete. Proceed to the wiring section from here.

How to Wire the Series 965

The Series 965 wiring is illustrated by model number option. Check the unit sticker on the control and compare your model number to those shown here and also the model number breakdown in the Appendix of this manual.

All outputs are referenced to a de-energized state. The final wiring figure is a typical system example.

When you apply power without sensor inputs on the terminal strip, the Series 965 displays **----** in the upper display, and a **0** in the lower display, except for 0-5V_{DC} (dc) or 4-20mA process input units. Press the A/M key twice, and **E-7** is displayed for one second. This error indicates an open sensor or A/D error. Remove power to the control and connect the sensor properly, see pages 8 and 9. All wiring and fusing must conform to the National Electric Code and to any locally applicable codes as well.

High Voltage

Model # 965A - 3 _ _ **0** - 00 _ _

**100 to 240 V~ (ac),
nominal
(85 to 264 actual)**

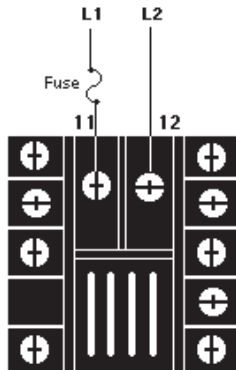

WARNING:
To avoid potential electric shock, use National Electric Code (NEC) safety practices when wiring and connecting this unit to a power source and to electrical sensors or peripheral devices.

NOTE:
Taking the unit out of the case is not a normal operating condition and should only be done by a qualified maintenance installation technician. Power to the case should be disconnected before removing or installing the controller into its case.

Figure 6 - High Voltage Power Wiring

Low Voltage

Model # 965A - 3 _ _ **1** - 00 _ _



12-24V~ (ac/dc)

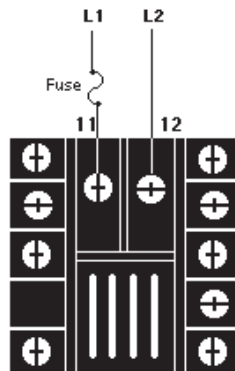

Figure 7 - Low Voltage Power Wiring



WARNING:
If high voltage is applied to the low voltage unit, irreversible damage will occur.

Sensor Installation Guidelines

We suggest you mount the sensor at a location in your process or system where it reads an average temperature. Put the sensor as near as possible to the material or space you want to control. Air flow past this sensor should be moderate. The sensor should be thermally insulated from the sensor mounting.

See Chapter 4 for more information on DIP switch location and orientation.

Thermocouple Input

Extension wire for thermocouples must be of the same alloy as the thermocouple itself to limit errors.

NOTE:
When an external device with a non-isolated circuit common is connected to the 4-20mA or dc output, you must use an isolated or ungrounded thermocouple.

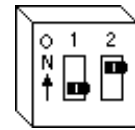
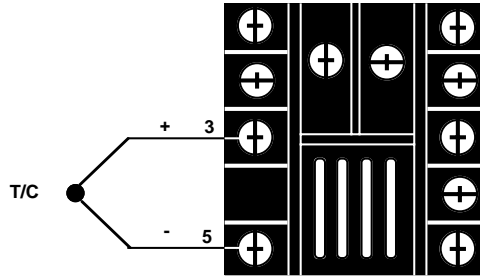

DIP Switch Orientation

Figure 8 - Thermocouple Sensor Input Wiring



CAUTION:
Process input does not have sensor break protection. Outputs can remain full on.

0-5V_{dc} (dc) Process Input

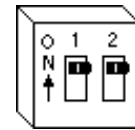

DIP Switch Orientation

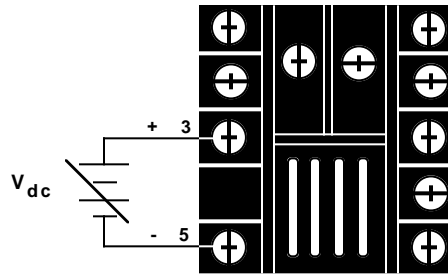

Input impedance: 10K Ω

Figure 9 - 0-5V_{dc} (dc) Process Sensor Input Wiring

RTD, 2- or 3-wire

There could be a + 2°F input error for every 1Ω of lead length resistance when using a 2-wire RTD. That resistance, when added to the RTD element resistance, will result in erroneous input to the instrument. To overcome this problem, use a 3-wire RTD sensor, which compensates for lead length resistance. When extension wire is used for a 3-wire RTD, all wires must have the same electrical resistance (i.e. same gauge, copper stranded, same length).

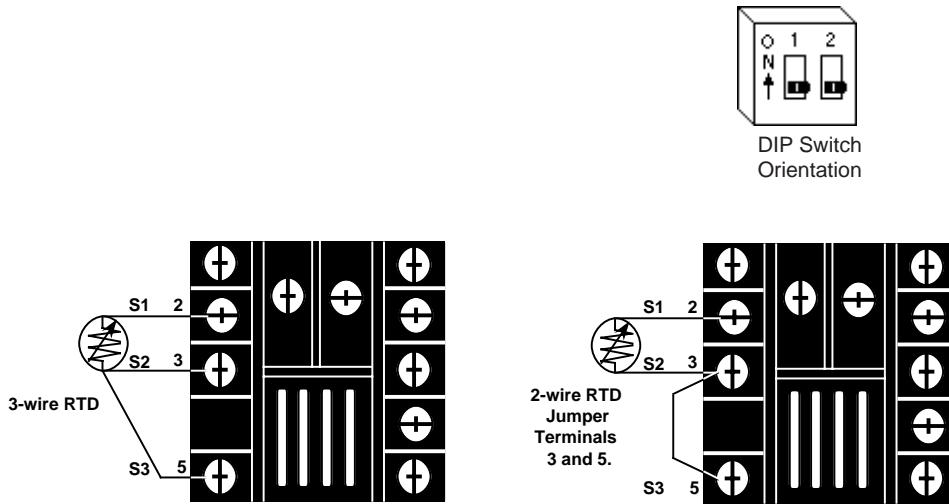
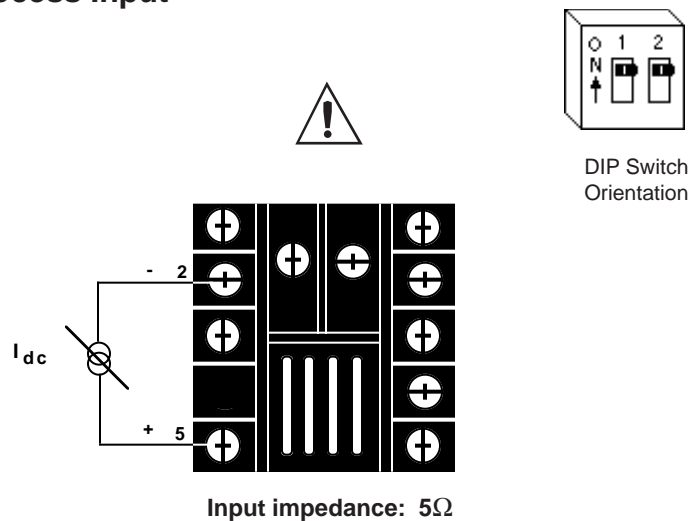

Figure 10 - 2- or 3-wire RTD Sensor Input Wiring

4 - 20mA Process Input



CAUTION:
Process input does not have sensor break protection. Outputs can remain full on.

Figure 11 - 4-20mA Process Sensor Input Wiring

Output 1 Wiring

Switched DC Output

Model # 965A - 3 **C** _ _ - 00 _ _

Figure 12 - Switched dc Output Wiring

NOTE:

When an external device with a non-isolated circuit common is connected to the 4-20mA or Switched dc output, you must use an isolated or ungrounded thermo-couple.

Figure 13 - 5 Amp Mechanical Relay Wiring

NOTE:

Switching inductive loads (relay coils, solenoids, etc.) with the mechanical relay, switched dc or solid-state relay output options requires using an R.C. suppressor. Watlow carries the R.C suppressor Quencharc brand name, which is a trademark of ITW Pakron. Watlow Part No. 0804-0147-0000.

Figure 14 - 4-20mA Process Wiring

Mechanical Relay Without Contact Suppression, Form C, 5 Amp

Model # 965A - 3 **D** _ _ - 00 _ _

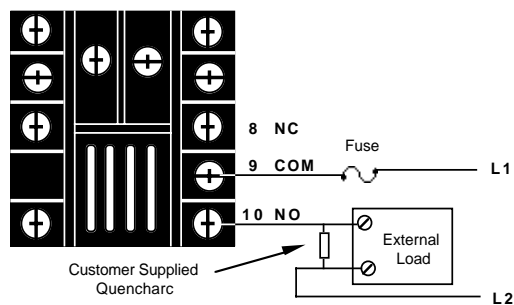
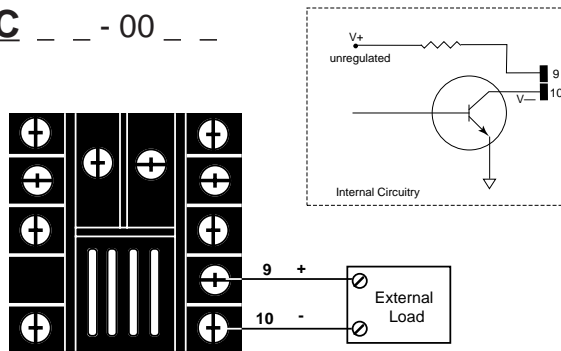

Process, 4-20mA

Model # 965A - 3 **F** _ _ - 00 _ _

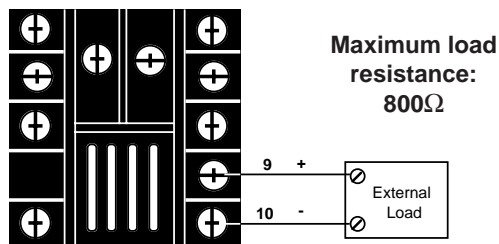

Solid-state Relay Without Contact Suppression, 0.5 Amp

Model # 965A - 3 **K** _ _ - 00 _ _

Figure 15 - 0.5 Amp Solid-state Relay Without Contact Suppression Wiring

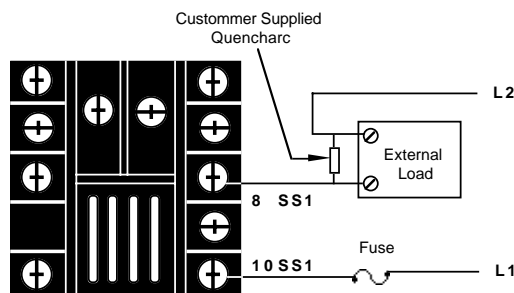

Switched DC Output

Model # 965A - 3 C - 00 - -

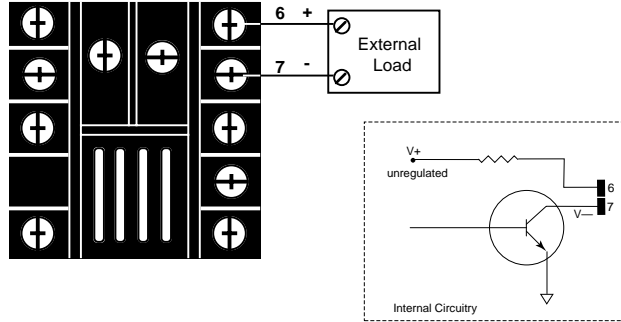

NOTE:
For more information on alarms see page 24.

Figure 16 - Switched dc Output Wiring

Mechanical Relay Without Contact Suppression, Form C, 5 Amp

Model # 965A - 3 D - 00 - -

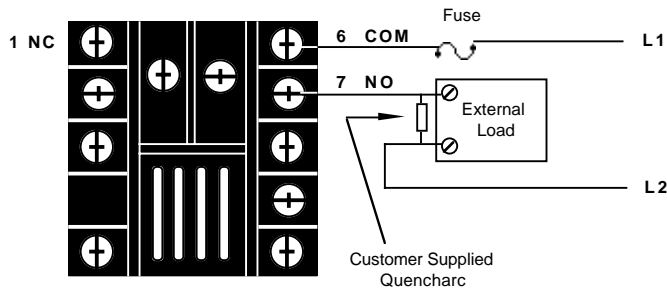
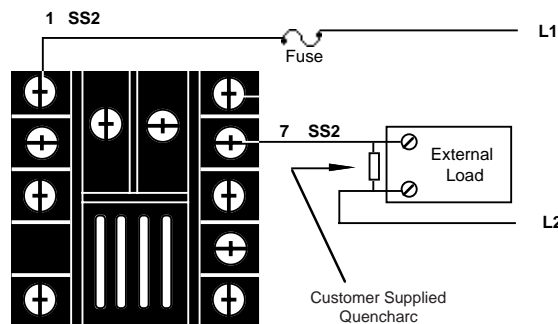

Figure 17 - 5 Amp Mechanical Relay Wiring

NOTE:
Switching inductive loads (relay coils, solenoids, etc.) with the mechanical relay, switched dc or solid-state relay output options requires using an RC suppressor. Watlow carries the RC suppressor Quencharc brand name, which is a trademark of ITW Pakron. Watlow Part No. 0804-0147-0000.

Solid-state Relay Without Contact Suppression, 0.5 Amp

Model # 965A - 3 K - 00 - -



NOTE:
Output is in open State in Alarm Condition.

Figure 18 - 0.5 Amp Solid-state Relay Without Contact Suppression Wiring

Wiring Example

Figure 19 - System Wiring Example



WARNING:

All wiring and fusing must conform to the National Electric Code NFPA70. Contact your local board for additional information. Failure to observe NEC safety guidelines could result in injury to personnel or damage to property.



CAUTION:

Watlow mercury relay loads must have a unity power factor. For RESISTIVE LOADS ONLY.

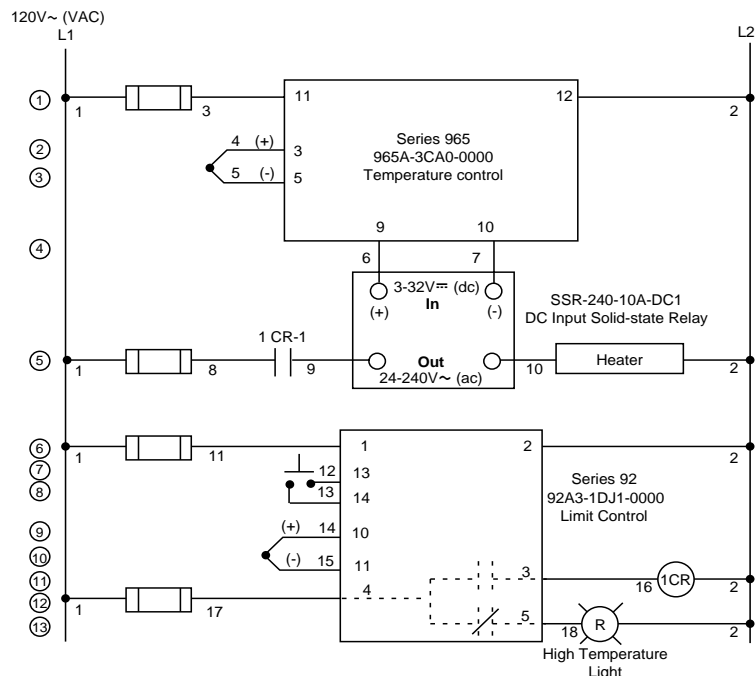
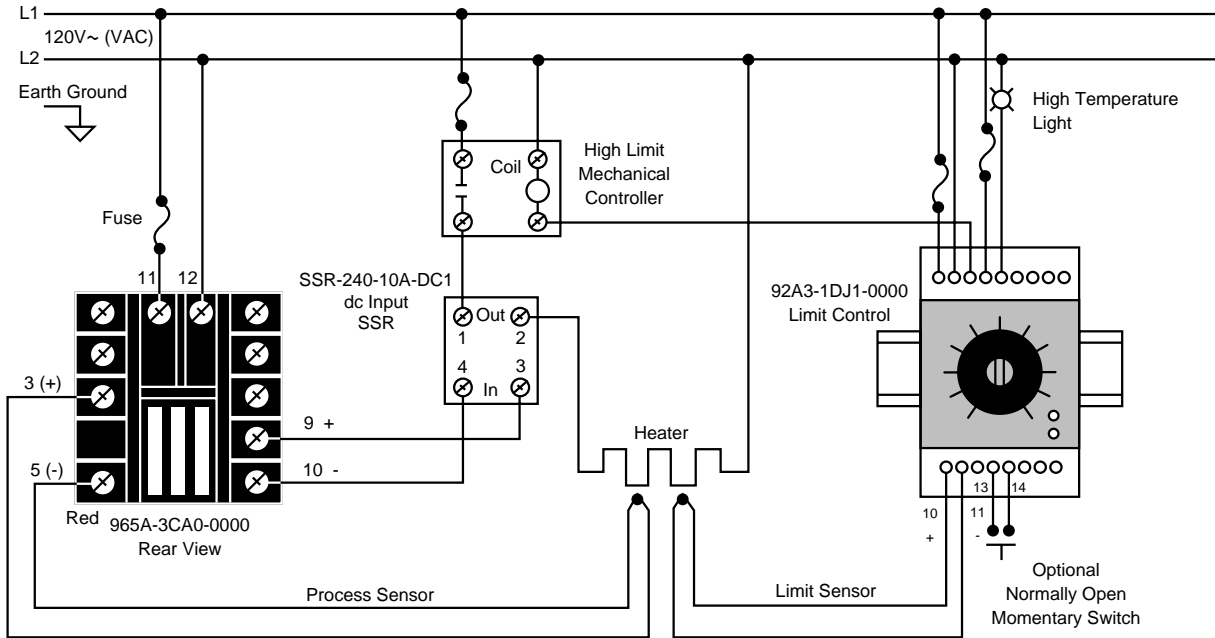

- 965A-3CA0-0000**
- 1 Not Used
 - 2 S1, I-
 - 3 S2, TC+, V+
 - 4 Not Used
 - 5 S3, TC-, V-, I+
 - 6 Not Used
 - 7 Not Used
 - 8 Not Used
 - 9 DC +1
 - 10 DC -1
 - 11 L1
 - 12 L2

Chapter 3

How to Use the Keys and Displays

Figure 20 - Series 965 Keys and Displays

After one minute with no key activations, the control reverts to the process value in the upper display and the set point in the lower display.

Upper Display

Red or green, 0.3" (8 mm) high, seven segment, four digit LED display, indicating either process, actual temperature, the operating parameter values or an open sensor. When powering up, the Process display will be blank for five seconds. This display can be blank by setting **dSP** to **SEL**. See page 18.

Lower Display

Red or green, 0.3" (8 mm) high, seven-segment, four-digit LED display, indicating the set point, output value, parameters for data in the upper display, or error and alarm codes. This display can be blank by setting **dSP** to **Pro**. See page 18.



L1
When lit, this LED tells you when Output 1 is energized.

L2
When lit, this LED tells you when Output 2 is active. This output can be configured as a control or alarm output.

MN
Lit when the control is in Manual operation. Press the A/M key twice to enter Automatic operation. When blinking, this indicates that pressing the A/M key toggles between Auto and Manual. After five seconds without pressing the A/M key, the LED stops blinking, and returns to its previous state.

Mode Key
Steps the control through the Operating Menu; also, in the Auto mode, new data is self entering in five seconds.

Up-arrow Key
Increases the value of the displayed parameter. A light touch increases the value by one. Holding the key down increases the value at a rapid rate. New data is self entering in five seconds.

Down-arrow Key
Decreases the value of the displayed parameter. A light touch decreases the value by one. Holding the key down decreases the displayed value at a rapid rate. New data is self entering in five seconds.

A/M Key
Pressed once, it clears any latched alarms and toggles between Auto and Manual mode. If pressed again within five seconds it will change from Auto to Manual or vice versa. While in Manual mode, percent power is in the lower display.

Up-arrow/Down-arrow Keys
When pressed simultaneously for three seconds, the Setup Menu appears displaying the **LOF** parameter. Continue to press the Up-arrow/Down-arrow keys, and the Calibration Menu appears.

How To Set Up The Series 965

Setting up the Series 965 is a simple process. First set the DIP switches to match your input type. Refer to the orientation below and Page 16 for the In parameter. Next, configure the 965's features to your application in the Setup Menu, then enter values in the Operating Menu. Both tasks use the MODE key to move through the menus and the Up-arrow/Down-arrow keys to select data.

Before entering information in the Setup menu, set the dFL parameter. If selected as US: °F, proportion band in degrees, reset rate are the defaults. If selected as SI: °C, proportional band in % of span, derivative and integral are the defaults. **Changing the dFL prompt will set parameters to their factory default. Document all current parameter settings first.** See Appendix 2 in the calibration section to change this parameter.

How to Set the Input Type DIP Switch



WARNING:
Remove power from the control before removing the chassis from the case or changing the DIP switches.

The Series 965 input type can be user selectable at any time via a Dual In-line Package (DIP) switch inside the control, located on the left (viewed from the bottom). To set the DIP switch, remove the control chassis from the case. Holding each side of the bezel, press in firmly on the side grips until the tabs release. You may need to rock the bezel back and forth several times to release the chassis.

The locations of the board and switches appear in Figure 21. Refer to the input types below for DIP switch orientation. DIP switch selection must match the sensor selected under the In parameter in the Setup Menu. Set the software selection for the input type to match. See Page 16.

Figure 21 -
DIP Switch Location
and Orientation

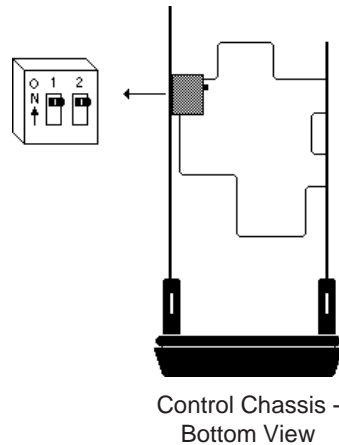

Input Types

Thermocouple

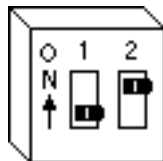

RTD

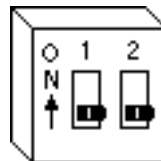

Process

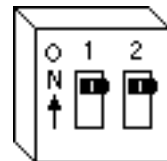

Entering the Setup Menu

The Setup Menu displays the parameters that configure the Series 965's features to your application.

Enter the Setup Menu by pressing the Up-arrow and Down-arrow keys simultaneously for 3 seconds. The lower display shows the LOC parameter, and the upper display shows its current level. All keys are inactive until you release both keys. You can reach the LOC parameter from anywhere.

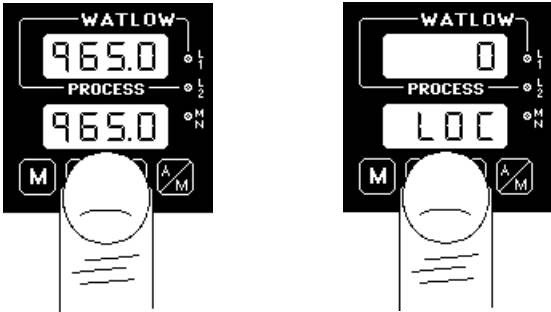
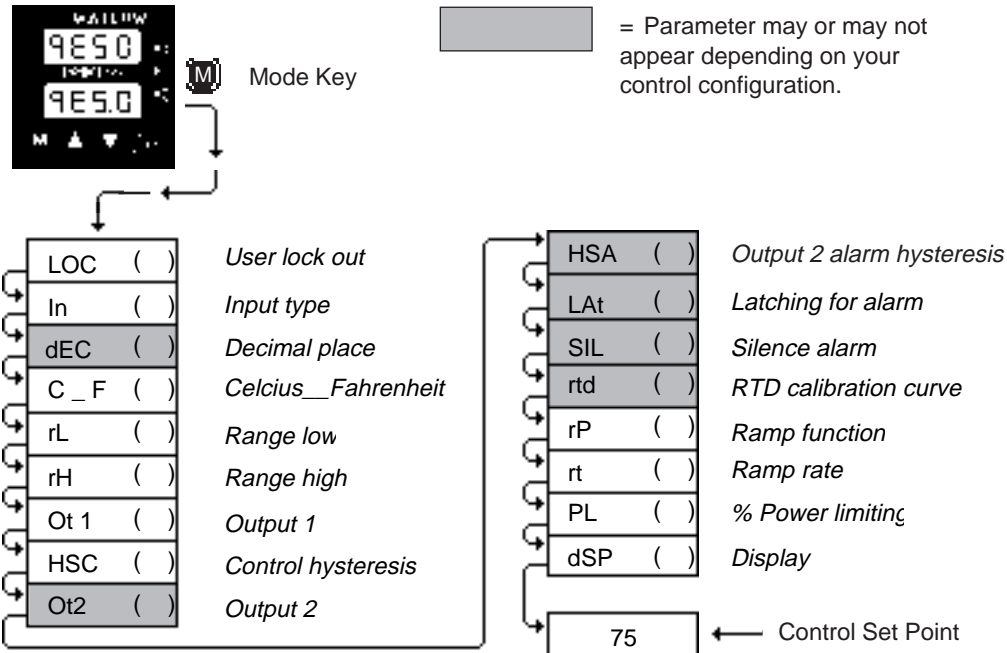

Figure 22 - Entering the Setup Menu

You will not see all parameters in this menu, depending on the unit's configuration and model number. After stepping through the menu it returns to the control set point parameter under the Operation Menu.



NOTE:
While in the Setup Menu, all outputs are off.

Figure 23 - The Setup Menu

Setup Parameters

When you are at the top of the menu, the Series 965 displays the user level of operation in the upper display, and the LOC parameter in the lower display.

Press the MODE key and the value of the next parameter appears in the upper display, and the parameter appears in the lower display.

LOC

Lock: Selects the level of operator lock-out as defined below.

Range: 0 - 4 **Default:** 0

NOTE:
Set the LOC parameter value as the final step in programming the Series 965 controller to prevent locking yourself out of the Operations and Setup Menu during initial programming.

LOC 0: All operating parameters may be viewed or changed. Manual operation **is** permitted. When in manual operation, percent power is adjustable. Bumpless transfer to manual mode can occur on sensor break.

LOC 1: The set point, actual, and alarm settings are the only visible parameters, set point **is** adjustable in this level. Manual operation and auto-tune **are** permitted. When in manual operation, percent power is adjustable. Bumpless transfer to manual mode can occur on sensor break.

LOC 2: The set point, actual, and alarm settings are the only visible parameters, set point **is** adjustable in this level. Manual operation **is** permitted. When in manual operation, percent power is adjustable. Bumpless transfer to manual mode can occur on sensor break.

LOC 3: The set point and actual are the only visible parameters, set point **is** adjustable in this level. Manual operation is **not** permitted. Bumpless transfer is defeated and outputs are disabled on sensor break.

LOC 4: The set point and actual are the only visible parameters, set point is **not** adjustable in this level of lock-out. Manual operation is **not** permitted. Bumpless transfer is defeated and outputs are disabled on sensor break.

NOTE:
Process input does not have sensor break protection or bumpless transfer.

In

Input: Selects the sensor input type. The internal DIP switch must also match the In parameter. See Figure 21 on Page 14 for DIP switch orientation, and see Table 1 on Page 18 for input type temperature ranges.

Range: J, K (appears as H), t, n, S, rtd, rt.d, 0-5, 420 **Default:** J

dEC

Decimal: Selects the location of the decimal point for all process related data. This parameter only appears if the In parameter is 0-5 or 420. Make sure the internal DIP switch matches the In parameter.

Range: 0, 0.0, 0.00 **Default:** 0

C_F

Celsius _ Fahrenheit: Selects the units of temperature measurement for the control. This parameter only appears if the In parameter is a thermocouple or RTD input. The default is dependent on the dFL parameter located in the Calibration menu. Refer to the Appendix. **Range:** C or F

If dFL = US: **Default:** F If dFL = SI: **Default:** C

rL

Range Low: Selects the low limit of the set point. Also used to set the low end of the process input. 0.0V \approx (VDC) and 4mA represent Range Low (rL) for process input. The process input is linearly scaled between rL and rH. See the model number and specification in the Appendix for range values, or refer to Table 1 on Page 18. **Range:** Sensor range low to rH

Default: Low limit of sensor type/-500 for process input

Range High: Selects the high limit of the operating range. Also used to set the high end of the process input. 5.0V \Rightarrow (dc) and 20mA represent Range High (rH) for process input. The process input is linearly scaled between rL and rH. See the model number and specification information in the Appendix for your range values, or refer to Table 1 on Page 18. **Range:** Sensor range high to rL **Default:** High limit of sensor type/9999 for process input

rH

Output 1: Selects the action for the primary output. Action in response to the difference between set point and process variable. Select ht (heat) for reverse acting or select CL (cool) for direct acting. **Range:** ht, CL **Default:** ht

Ot1

Hysteresis-Control: Selects the switching hysteresis for Output 1 and 2 when you select 0 (ON/OFF) under the Pb1 parameter and Ot2 = Con.
Range: 1 to 99, 0.1 to 9.9, 0.01 to 0.99/1 to 55, 0.1 to 5.5, 0.01 to 0.55
Default: 3, 0.3, 0.03°F/2, 0.2, 0.02

HSC

Output 2: Selects the output action for the secondary output.
Range: Con Control mode opposite Output 1 (heat or cool) **Default:** Con
 PrA Process alarm with alarm message displayed
 Pr Process alarm with no alarm message displayed
 dEA Deviation alarm with alarm message displayed
 dE Deviation alarm with no alarm message displayed
 no None

Ot2

Hysteresis - Alarm: Selects the switching hysteresis for Output 2 when Ot2 is an alarm. This parameter only appears if Ot2 \neq Con or no. See Page 19 for the Pb1 parameter. **Range:** 1 to 9999, 0.1 to 999.9, 0.01 to 99.99/1 to 5555, 0.1 to 555.5, 0.01 to 55.5 **Default:** 3, 0.3, 0.03/2, 0.2, 0.02

HSA

Latching: Selects whether the alarm is latching or non-latching. Latching alarms must be cleared before the alarm output will reset. Non-latching automatically resets the alarm output when the condition clears. This parameter will not appear if Ot2 = Con or no. **Range:** LAt or nLA **Default:** nLA

LAt

Silencing: Selects alarm silencing (inhibit) for the alarm. This parameter appears only when Ot2 = dEA or dE. For more information see Chapter 5, "Using Alarms."
Range: On or OFF **Default:** OFF

SIL

RTD: Selects the RTD calibration curve for RTD inputs. This parameter will not appear unless In = rtd or rt.d. JIS = 0.003916 Ω /°C, DIN = 0.003850 Ω /°C. **Range:** din or JIS **Default:** din

rtd

Ramping: Choose **Str**, and the set point ramps at the selected rate in °/hr from process (actual) temperature to set point, when power is applied to the control (start up). It will not ramp with a set point change. **On** is the same as Str plus it ramps *with* a set point change. It ramps from the previous set point to a new one at the selected ramp rate. **OFF** is for no ramping action. When ramping, the lower display alternately flashes rP. The set point displayed is the desired end set point. The ramping setpoint is not shown. Entering the Setup menu or manual operation disables the outputs and ramp. Once you exit either one, the 965 controls to the last entered set point. **Range:** Str, On, OFF **Default:** OFF

r P

Rate: Selects the ramping rate in degrees per hour. This parameter will not appear if rP = OFF. **Range:** 0 to 9999 **Default:** 100°/hr

r t

Setup

PL

Power Limiting: The power limiting function in % power for heat.
Range: Dependent on output type. -100 to 100 **Default:** 100

dSP

Display: Selects which displays are active or viewable. Five seconds after selected, the appropriate display goes blank. Press MODE, Up-arrow or Down-arrow to override this feature and cause the current value to be displayed for 5 seconds.

Range: nor Normal displays **Default:** nor
 SEt Set Point - Lower display only
 Pro Process - Upper display only

Table 1 -
Input Ranges.

Input Type	Sensor Range Low	Sensor Range High
J	32°F/0°C	1382°F/750°C
K (appears as H)	-328°F/-200°C	2282°F/1250°C
t	-328°F/-200°C	662°F/350°C
n	32°F/0°C	2282°F/1250°C
S	32°F/0°C	2642°F/1450°C
rtd (1°)	-328°F/-200°C	1292°F/700°C
rt.d (0.1°)	-199.9/199.9	999.9/700.0
4-20mA	4mA/-999 units	20mA/9999 units
0-5V _{DC} (dc)	0V _{DC} (dc)/-999 units	5V _{DC} (dc)/9999 units

Table 2 -
Setup Menu
Prompts and
Descriptions.

Setup Menu

Do not enter any values here; make photocopies instead.

Parameter	Value	Range	Factory Default	Appears If:
LOC		0 - 4	0	
In		J, K (appears as H), t, n, S, rtd, rt.d, 0-5, 420	J	DIP switch selectable.
dEC		0, 0.0, 0.00	0	In = 0-5 or 420
C _ F		C or F	Dependent on dFL.	In = J,K,t,n,S,rtd,rt.d
rL		rL to rH	Input dependent.	
rH		rH to rL	Input dependent.	
Ot1		ht or CL	ht	
HSC		1 - 99, 0.1 - 9.9, 0.01 - 0.99 1 to 55, 0.1 to 5.5, 0.01 to 0.55	3, 0.3, 0.03 3, 0.3, 0.03/2, 0.2, 0.02	
Ot2		Con = Control PrA = Process Alarm Pr = Process with no alarm message dEA = Deviation alarm dE = Deviation with no alarm message no = None	Con	
HSA		1 - 9999, 0.1 - 999.9, 0.01 - 99.99 1 - 5555, 0.1 - 555.5, 0.01 - 55.55	3, 0.3, 0.03°F 2, 0.2, 0.02°C	Ot2 ≠ Con or no
LAt		LAt or nLA	nLA	Ot2 ≠ Con or no
SIL		On or OFF	OFF	Ot2 = dEA or dE
rtd		JIS or din	din	In = rtd or rt.d
r P		Str = Ramping on power up on = Ramping to set point at all times OFF = None	OFF	
rt		0 to 9999	100°/hr	rP ≠ OFF
PL		0 to 100	100	
dSP		nor = normal SEt = Set Point (lower only) Pro = Process (upper only)	nor	

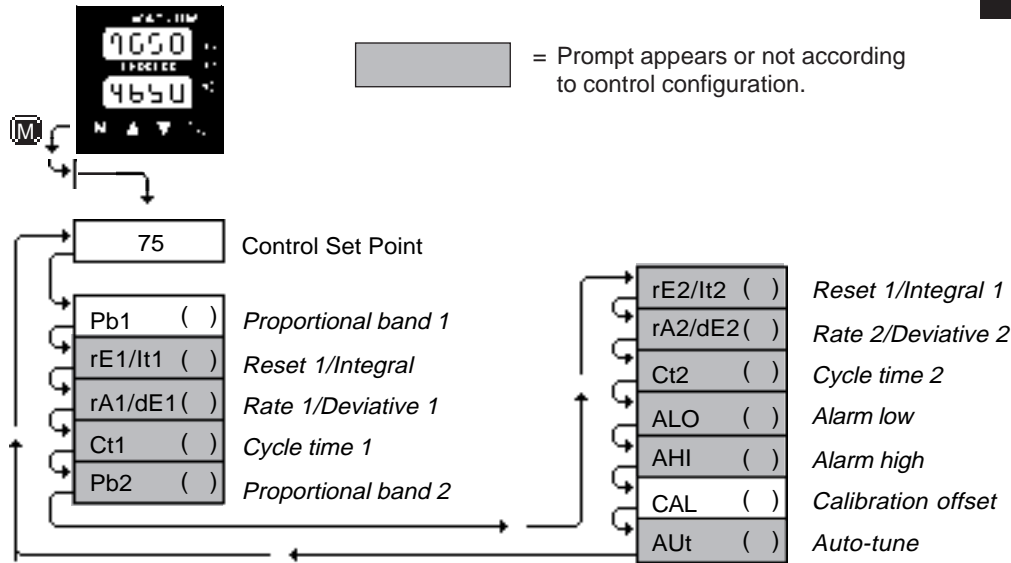

NOTE:
The upper display will always return to the process value after 1 minute without key strokes.

Figure 24 - The Operation Menu.

Operation Parameters

Set Point: Sets the operating set point for Output 1. Represents the process value the system tries to achieve for Output 1. "SP" does not appear, the control set point **value** will. The lower display may be blank if dSP = Pro. If in a ramping mode, the lower display alternately flashes the desired end set point and rP.

[SP]

Proportional Band 1 & 2 : A proportional band expressed in degrees or % of span, within which a proportioning function is active for Output 1 or 2. When Pb1 = 0, the unit functions as an on/off control on Output 1 and 2. Pb2 will not appear if Pb1 = 0 or Ot2 ≠ Con. The switching differential is determined by the HSC parameter.

Pb1
Pb2

If dFL = US: **Range** Pb1: 0 to 999°F/0 to 555°C/0 to 999 Units; 0.0 to 9.9°F/0.0 to 5.5°C/0.0 to 9.9 units, **Pb2:** The same as Pb1 except lower limit is 1.

Defaults: Pb1 = 25°F/2.5°F Pb2 = 25

If dFL = SI: **Range:** 0 to 999.9% of span **Defaults:** Pb1 = 3.0% Pb2 = 3.0%

Reset /Integral 1 & 2: An integral control action for Output 1 or 2 that automatically eliminates offset, or "droop," between set point and actual process temperature. **rE1/It1:** Will not appear if Pb1 = 0. **rE2/It2:** Appears if Pb1 ≠ 0 and Ot2 = Con. Either reset (rE) or integral (It) will appear depending on how the dFL parameter is set in the Calibration menu. See Appendix II.

rE1/It1
rE2/It2

If dFL = US: **Range:** 0 to 9.99 repeats/minute **Default:** 0.00

If dFL = SI: **Range:** 00.1 to 9.99 minutes per repeat **Default:** 0.00

Rate /Derivative 1 & 2 : The rate (derivative) function for Output 1 or Output 2. Eliminate over shoot on start up, or after the set point changes. **rA1/dE1:** Will not appear if Pb1 = 0. **rA2/dE2:** Appears if Pb1 ≠ 0 and Ot2 = Con. Either rate (rA) or derivative (dE) appears depending on how dFL is set in the Calibration menu. If dFL = US or SI: **Range:** 0 to 9.99 minutes **Default:** 0.00

rA1/dE1
rA2/dE2

Cycle Time 1 & 2: Time for a controller to complete one time proportioned cycle for Output 1 or Output 2; expressed in seconds. **Ct1:** Will not appear if Pb1 = 0, or Output 1 is 4-20mA. **Ct2:** Will not appear if Pb1 = 0 or Ot2 ≠ Con. **If a mechanical relay or contactor is switching power to the load, a longer cycle time may be desirable to minimize wear on the mechanical components. Typical life of a mechanical relay is 100,000 cycles.**

Ct1
Ct2

Range: 0.1 to 999.9 **Default:** 5.0

Operation

ALO

Alarm Low: Represents the low process alarm or low deviation alarm. This parameter will not appear if Ot 2 = no or Con.

If Ot2 = dEA or dE: **Range:** -999 to 0

Default: -999

If Ot2 = PrA or Pr: **Range:** rL to AHI

Default: rL

AHI

Alarm High: Represents the high process alarm or high deviation alarm. This parameter will not appear if Ot2 = no or Con.

If Ot2 = dEA or dE: **Range:** 0 to 999

Default: 999

If Ot2 = PrA or Pr: **Range:** ALO to rH

Default: rH

CAL

Calibration Offset: Adds or subtracts degrees from the input signal.

Range: -180°F to 180°F/-100°C to 100°C/-180 units to 180 units; or

-18.0°F to 18.0°F/-10.0°C to 10.0°C

Default: 0

AUt

Auto-Tune: Initiates auto-tune.

Range: 0 = off, 1 = slow, 2 = medium, 3 = fast

Default: 0

**Table 3 -
Operation Menu
Prompts and
Descriptions.**

Operation Menu

Use this page as a master copy for your Series 965 Operation Parameters.
Do not enter any values here; make photocopies instead.

Operation Parameters	Value	Range	Factory Default
Pb1		If dFL = US: 0 - 999°F/0 - 555°C/0 - 999 Units 0 - 99.9°F/0 - 55.5°C/0 - 99.9 Units 0=ON/OFF control. HSC =switch diff. If dFL = SI: 0.0 to 999.9% of span	25°F 2.5°F 3%
rE1		0.00 to 9.99 repeats/minute 0.00 = No Reset. Won't appear if Pb1 = 0 or dFL = SI.	0.00 repeats/minute
It1		0.0 - 99.9 minutes/rpt. 0.00 = No Integral. Won't appear if Pb1 = 0 or dFL = US.	00.0 minutes/repeat
rA1		0.00 to 9.99 minutes 0.00 = No Rate. Will not appear if Pb1 = 0 or dFL = SI.	0.00 minutes
dE1		0.00 - 9.99 minutes. 0.00 = No Derivative. Won't appear if Pb 1 = 0 or dFL = US.	0.00 minutes
Ct1		0.1 to 999.9 Won't appear if Pb1 = 0, or 4-20mA.	5.0 seconds
Pb2		Same as Pb1. Pb2 lower limit = 1, 0.1, 0.01	
rE2		Same range as rE1.	
It2		Same range as It1.	
rA2		Same range as rA1.	
dE2		Same range as dE1.	
Ct2		Same range as Ct1.	
ALO - Deviation dE Process Pr		-999 to 0 rL to AHI Will not appear if Ot2 = no or Con.	-999 rL
AHI - Deviation dE Process Pr		0 to 999 ALO to rH Will not appear if Ot2 = no or Con.	999 rH
CAL		±18°F/±10°C/±18 Units	0
AUt		0-3	0

Chapter 5

How to Tune and Operate

Auto-tuning (Heat and/or Cool)

The Series 965 can automatically tune the PID parameters to fit the characteristics of your particular thermal system.

The auto-tuning procedure operates on a thermal response value — slow, medium, or fast. Use the slow thermal response when your process does not need to reach set point too rapidly, or if it usually does not often exceed set point. A fast thermal response produces a rapid temperature change over a short period of time.

Once the auto-tune sequence has begun, the Output 1 heat proportional band is set to 0 and the control goes into an on/off mode of control at 90% of the established set point. The displayed set point remains unchanged.

Once the control finishes "learning" the system, it returns to a standard PID control with the PID values automatically set as a result of auto-tuning. See Manual Tuning on the next page to set the cool PID parameters. Any change of the set point, while in auto-tune, re-initiates the auto-tune procedure.

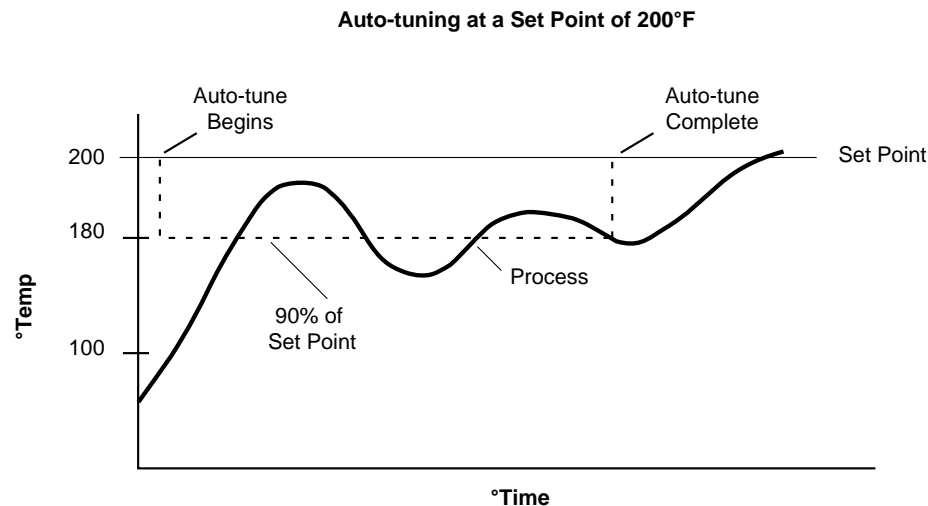

**Figure 25 -
Auto-tuning at a
Set Point of 200°F.**

In order for the 965 to successfully complete auto-tune, the process must cross 90% of set point four times within 80 minutes after auto-tune has started. If this does not happen within the 80 minute time limit, the Pb remains at 0 and the control functions in an on/off mode.

To start auto-tuning:

1. **Press the MODE key** until the **AUt** prompt appears in the data display.
2. **Select a thermal response value**, 1=slow, 2=medium, and 3=fast, using the Up-arrow/Down-arrow keys. A thermal response value of 2 satisfactorily tunes most thermal systems.
3. **Press the MODE key.** While the control is in the tuning mode, the lower display alternately displays the normal information and the prompt **At**. The time between alternations is 1 second.
4. **When tuning is complete**, the displays return to their previous state and **AUt** reverts to 0. The 965 installs appropriate PID tuning parameters and saves them in the non-volatile memory. **If a mechanical relay or contactor is switching power to the load, a longer cycle time may be desirable to minimize wear on the mechanical components. Typical life of a mechanical relay is 100,000 cycles.**

To abort auto-tuning either reset the **AUt** parameter to 0, press the A/M key twice, or cycle power off and on. In all cases, aborting auto-tune restores all values to those previous to auto-tuning.

Manual Tuning

For optimum control performance, tune the Series 965 to your thermal system. The tuning settings here are for a broad spectrum of applications; your system may have somewhat different requirements. **NOTE: This is a slow procedure, taking from minutes to hours to obtain optimum value.**

NOTE:

Tune heating outputs at a set point above ambient temperature.

Tune cooling outputs at a set point below ambient temperature.

1. **Apply power to the Series 965** and enter a set point. Begin with these Operation parameters: **Pb** = 1, **rE/It** = 0.00, **rA/dE1** = 0.00, **Ct** = 5.0, **CAL** = 0, **AUt** = 0.
2. **Proportional Band Adjustment:** Gradually increase **Pb** until the upper display temperature stabilizes to a constant value. The process temperature will not be right on set point because the initial reset value is 0.00 repeats per minute. (When **Pb** = 0; **rE/It** and **rA/dE1** are inoperative, and the 965 functions as a simple ON/OFF control.) The HSC parameter determines the switching differential value.
3. **Reset/Integral Adjustment:** Gradually increase **rE**, or decrease **It** until the upper display temperature begins to oscillate or "hunt." Then slowly decrease **rE** or increase **It** until the upper display stabilizes again near set point.
4. **Cycle Time Adjustment:** Set **Ct** as required. Faster cycle times sometimes achieve the best system control. However, if a mechanical contactor or solenoid is switching power to the load, a longer cycle time may be desirable

to minimize wear on the mechanical components. Experiment until the cycle time is consistent with the quality of control you want. Ct will not appear on units with a process output.

- 5. Rate/Derivative Adjustment:** Increase **rA/dE** to 1.00 minute. Then raise set point by 20° to 30°F, or 11° to 17°C. Observe the system's approach to set point. If the load temperature overshoots set point, increase **rA/dE** to 2.00 minutes.

Raise set point by 20 to 30°F, or 11 to 17°C and watch the approach to the new set point. If you increase **rA/dE1** too much, approach to set point is very sluggish. Repeat as necessary until the system rises to the new set point without overshooting or approaching the set point too slowly.

- 6. Calibration Offset Adjustment:** You may want your system to control to a temperature other than the value coming from the input sensor. If so, measure the difference between that temperature (perhaps at another point in the system) and the process value showing in the upper display. Then enter the **CAL** offset value you want. Calibration offset adds or subtracts degrees from the value of the input signal.

Manual and Automatic Operation

To change from auto to manual operation, press the A/M key twice.

Manual operation provides open loop control of the outputs from a range of -100% (full cooling) to 100% (full heating) power. The 965 allows a negative output value only with a Cl (Cool) selection on either Ot1 or Ot2 = Con. Automatic operation provides closed loop on/off or PID control. When the operator transfers from a closed loop to an open loop, the 965 retains the power level from the closed loop control, referred to as bumpless transfer. When the 965 returns to closed loop control, it restores the previous set point temperature.

The MN LED indicates auto or manual operation. When the LED is on, the control is in manual operation. When the LED is off, it is in automatic operation. When the LED flashes, press the key again within five seconds to complete the change in operation.

When a sensor opens, the 965 switches from automatic to manual operation if LOC = 0, 1 or 2.

- If LOC = 0, 1 or 2 and the bumpless transfer conditions are met, process has stabilized at a $\pm 5\%$ power level for a 2 minute period prior to sensor break provided the power level is less than 75%. The 965 switches to manual operation at the last automatic power level.
- If LOC = 3 or 4, the 965 switches into manual operation at 0% power (outputs disabled).

When transferring from auto to manual operation, the control output(s) remains stable ("bumpless," smooth transition). When transferring from manual to automatic operation, the control output(s) may change significantly. In manual operation, the output value appears in the lower display; in automatic operation, the set point appears.

NOTE:
Process input does not have sensor break protection or bumpless transfer. Outputs selected as Ht (reverse acting) will be full on if sensor break occurs.

Using Alarms

NOTE:
When the alarm output is de-energized, the NO contact is open in the alarm condition.

The Series 965 has two alarm types, Process or Deviation. A **process alarm** sets an absolute temperature. When the process exceeds that absolute temperature limit an alarm occurs. The process alarm set points may be independently set high and low. Under the Setup Menu, select the type of alarm output with the Ot2 parameter. PrA = Process Alarm Pr = Process alarm with no alarm message displayed

A **Deviation alarm** alerts the operator when the process strays too far from set point. The operator can enter independent high and low alarm settings. The reference for the deviation alarm is the set point. Any change in set point causes a corresponding shift in the deviation alarm. dEA = Deviation Alarm dE = Deviation alarm with no alarm message displayed

Example: If your set point is 100°F/38°C, and a deviation alarm is set at +7°F/4°C as the high limit, and -5°F/3°C as the low limit, the high alarm trips at 107°F/41.6°C, and the low alarm at 95°F/35°C. If you change the set point to 130°F/54.4°C, the alarms follow the set point and trip at 137°F/59°C and 125°F/51.6°C.

Under the Setup Menu, select the type of alarm output with the Ot2 parameter. dEA = Deviation Alarm dE = Deviation alarm with no alarm message displayed

Both process and deviation alarms can be latching or non-latching. When the alarm condition is removed a **non-latching alarm automatically** clears the alarm output. You must **manually clear** a **latching alarm** before it will disappear.

Flashing "LO" or "HI" in the lower display indicates an alarm when Ot2 = PrA or dEA. The lower display alternately shows information from the current parameter and the "LO" or "HI" alarm message at one second intervals. The alarm output is de-energized and the L2 LED is lit.

To clear an alarm...

- **First correct the alarm condition, then...**
 - **If the alarm is latching...**
Clear it manually; press the A/M key once as soon as the process temperature is inside the HSA parameter alarm limit.
 - **If the alarm is non-latching...**
The alarm clears itself automatically as soon as the process temperature is inside the HSA parameter alarm limit.

Figure 26 - Alarm Display Examples

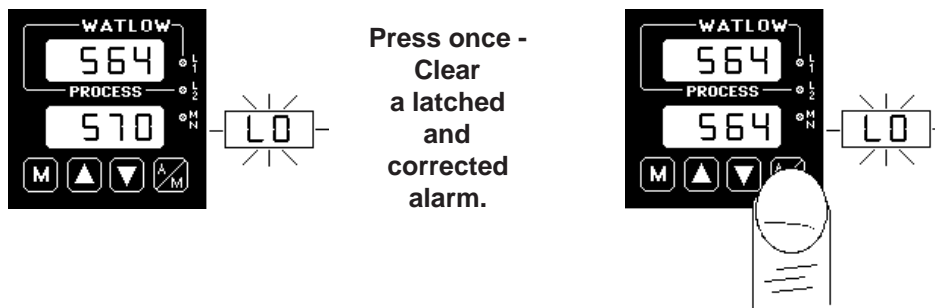

Alarm Silencing is available with the deviation alarm. When SIL is selected as "on," the operator must manually disable the alarm by pressing the A/M key once on initial power up (in either the latching or non-latching mode). Alarm silencing disables the alarm output relay. However, the L2 LED (also the lower display when Ot2 = dEA) shows an alarm condition until the process value is within the "safe" region of the deviation alarm band. Once the process value crosses into the "safe" region, both a latching or a non-latching alarm is ready. Any future deviation outside this safe band triggers an alarm.

Error Code Messages

Four dashes, "- - -", in the upper display indicate a Series 965 error. The error code is visible in the lower display.

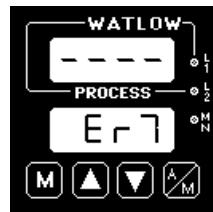

NOTE:

An alarm display will be masked by an error condition or when the control is in the Calibration or Setup Menus.

Er 2 - Sensor underrange error (only applies to RTD units)

The sensor input generated a value lower than the allowable signal range, or the A/D circuitry malfunctioned. Enter a valid input. Make sure the **In** parameter (selected in the Setup menu) and the DIP switch settings both match your sensor. Refer to the table below for the appropriate input type and range.

Er 4 - Configuration error

The unit's microprocessor is faulty; call the factory.

Er 5 - Non volatile checksum error

The nonvolatile memory checksum discovered a checksum error. Unless a momentary power interruption occurred while the unit was storing data, the nonvolatile memory is bad. Call the factory.

Er 6 - A/D underflow error

The A/D circuit is underrange. An open or reversed polarity sensor is the most likely cause. Check the sensor; if the connection is good and functions properly, call the factory. The A/D underrange voltage is too low to convert an A/D signal. Make sure the **In** parameter matches your sensor and DIP switches are set accordingly.

Er 7 - A/D overflow error

The A/D circuit is overrange. An open or reversed polarity sensor is the most likely cause. Check the sensor; if the connection is good, and the sensor functions properly, call the factory. The A/D overrange voltage is too high to convert an A/D signal. Make sure the **In** parameter matches your sensor and DIP switches are set accordingly.



CAUTION:

Electrical noise or a noise event, vibration or excess environmental moisture or temperature may cause Series 965 errors to occur. If the cause of an error is not otherwise apparent, check for these.

Error Code Actions

- **Er 2, Er 6, Er 7 result in these conditions:**

- **If operator access is LOC 0, 1 or 2 ...**

...and the control was in AUTO operation when the error occurred, it goes into manual (% power) operation. If the output power is less than 75% power, and a <5% change in power occurred within the last two minutes, the 965 switches into manual operation at the last automatic power level (bumpless transfer). If the control was in manual operation, it remains there. Press A/M twice to see the error code. The alarm output (if present) is in its alarm state (LED lit). The upper display reads "- - -". The lower display indicates the error code.

If the control was operating with stable output values when the error occurred, it continues to operate at those levels on a % power basis. If output values were not stable, the control outputs go to 0% power (OFF).

- **If operator access is LOC 3 or 4...**

The control remains in auto operation and the outputs go off. The A/M and MODE keys are inactive. The Up-arrow/Down-arrow keys may be used simultaneously to enter the Setup Menu. The alarm output (if present) is in its alarm state (LED lit). The upper display reads "- - - -". The lower display indicates the error code.

- **To clear a corrected error...**

- Press M (Mode key).

- **Er 4 and Er 5 result in these conditions:**

- The control is in auto operation with both outputs off.
- The alarm output, if present, are in their alarm state (de-energized with the LED lit).
- The upper display indicates the process value.
- The lower display indicates the error code.
- All keys are inactive.
- All Setup Menu parameters return to default values.
- The above conditions occur regardless of the value of LOC, or the presence of the Setup or Calibration Menus.

- **To clear a corrected error...**

- Cycle power to the control.

Appendix 1

Noise and Installation Guidelines

For wiring guidelines, refer to the IEEE Standard No. 518-1982, available from IEEE, Inc. 345 East 47th Street, New York, NY 10017.

Noise Sources

- Switches and relay contacts operating inductive loads such as motors, coils, solenoids, and relays, etc.
- Thyristors or other semiconductor devices which are not zero crossover-fired (randomly-fired or phase angle-fired devices).
- All welding machinery and heavy current carrying conductors.
- Fluorescent and neon lights.

Decreasing Noise Sensitivity

- Physical separation and wire routing must be given careful consideration in planning the system layout. For example, ac power supply lines should be bundled together and physically kept separate from input signal lines (sensor lines). A 12" (305 mm) minimum separation is usually effective. Keep all switched output signal lines (high power level) separate from input signal lines (sensor lines). Cross other wiring at 90° angles whenever crossing lines is unavoidable.
- Look at the system layout; identify and locate electrical noise sources such as solenoids, relay contacts, motors, etc. Route the wire bundles and cables as far away as possible from these noise sources. Don't mount relays or switching devices close to a microprocessor control. Don't have phase angle-fired devices in the same electrical enclosure or on the same power line with the control.
- Shielded cables should be used for all low power signal lines to protect from magnetic and electrostatic coupling of noise. Some simple pointers are:
 - ◇ Whenever possible, run low level signal lines unbroken from signal source to the control circuit.
 - ◇ Connect the shield to the control circuit common at the control end only. Never leave the shield unconnected at both ends. Never connect both shield ends to a common or ground.
 - ◇ Maintain shield continuity at daisy chain connection points by reconnecting the broken shield.
 - ◇ Assume no electrostatic shielding when using the shield as a signal return. If you must do this, use triaxial cable (electrostatically shielded coaxial cable).

- Use twisted pair wire any time control circuit signals must travel over two feet, or when you bundle them parallel with other wires.
- Select the size or gauge of wire by calculating the maximum circuit current and choosing the gauge meeting that requirement. Using greatly larger wire sizes than required generally increases the likelihood of electrostatic (capacitance) coupling of noise.
- Eliminate ground loops in the entire control system. You can spot the obvious loops by studying the "as-built" wiring diagram. There are also not-so-obvious ground loops resulting from connecting internal circuit commons in the manufacturer's equipment.
- Do not daisy chain ac power (or return) lines, or output signal (or return) lines to multiple control circuits. Use a direct line from the power source to each input requiring ac power. Avoid paralleling L1 (power lead) and L2 (return lead) to load power solenoids, contactors, and control circuits. If an application uses L1 (power lead) to switch a load, L2 (return lead) has the same switched signal and could couple unwanted noise into a control circuit.
- Tie all ground terminals together with one lead (usually green wire) tied to ground at one point. Don't connect ground to the control case if the control is in a grounded enclosure (preventing ground loops).
- Do not confuse chassis grounds (safety ground) with control circuit commons or with ac supply L2 (return or neutral line). Each return system wiring must be separate. Absolutely never use chassis ground (safety) as a conductor to return circuit current.

Eliminating Noise

- Use "snubbers" (QUENCHARC™ P/N: 0804-0147-0000) to filter out noise generated by relays, relay contacts, solenoids, motors, etc. A snubber is a simple filter device using a 0.1 μ f, 600 volt, non-polarized capacitor in series with a 100 Ω , 1/2 watt resistor. The device can be used on ac or dc circuits to effectively dampen noise at its source.
- The ultimate protection is an "uninterruptable" power supply. This "senses" the ac power line; when the line fluctuates, a battery powered 60Hz inverted circuit takes over, supplying power within one-half to one cycle of the ac line; very expensive.

Calibration

Before attempting to calibrate, make sure you read through the procedures carefully and have the proper equipment called for in each procedure. Make sure the DIP switches are in the proper position per input type. See Figure 21, Page 14.

Entering the Calibration Menu

In the Calibration Menu, various input signals must be supplied for the control to go through its auto calibration. The calibration menu can only be entered from the LOC parameter in the Setup Menu. Press the Up-arrow/Down-arrow keys simultaneously for 3 seconds (± 1 second). The CAL parameter appears in the lower display with "no" in the upper display.

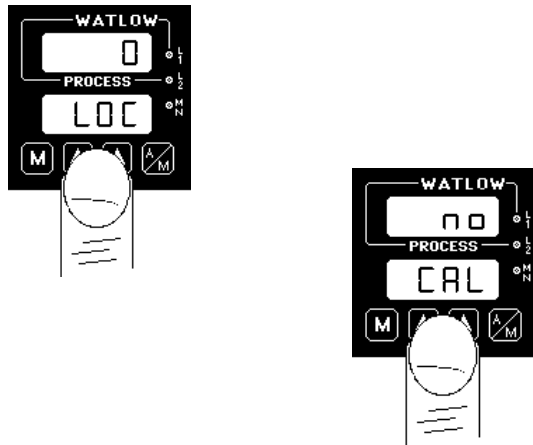

Figure 27 - Entering the Calibration Menu.

NOTE:
Calibration values will not be retained unless you are in the MANUAL mode. Do not enter the MANUAL mode until you are at the correct input parameters.

Any inadvertent change in the displayed data, when pressing the Up-arrow/Down-arrow keys, is ignored. Calibration values won't be retained unless you are in the manual mode. Press the Up-arrow/Down-arrow key to change the upper display to "YES." Press MODE to enter the calibration sequence.

Upon entering the calibration menu, the upper display window indicates CAL. It continues to indicate CAL (with the exception of calibration of the 4-20mA output) while the operator walks through the entire calibration parameter list. While calibrating the 4-20mA output, the upper display contains a numeric value to be slewed up or down until the output value is correct. The control uses the lower display to prompt the user as to what the input should be.

With the dFL parameter, select either U.S. parameters which include displaying °F, rate, reset, and proportional band in degrees or units. Or select SI (System International) and the displayed parameters are °C, integral, derivative, and proportional band in % of span.

Once the information has been properly established and maintained for at least 5 to 10 seconds, the MODE key may then be used to display the next prompt. After the final input is established, press the MODE key twice to return the unit to the configuration menu at the top of the parameter list.

NOTE:
While in the Calibration Menu, the control output(s) go off and the alarm output (if present) is on.

Restoring Factory Calibration

The rSt parameter restores the factory calibration values to the Series 965. If you calibrate your control incorrectly, you have the option to default to the original values. Once you leave the CAL menu, the values are entered.

1. Press the Up-arrow/Down-arrow keys simultaneously for three seconds. The LOC parameter appears in the lower display. Continue holding the Up-arrow/Down-arrow keys until the lower display reads CAL.
2. Press the Up-arrow key until YES appears in the upper display.
3. MODE through the calibration menu until rSt appears in the lower display.
4. Press the Up-arrow key until YES appears in the upper display.
5. Press the MODE key and the 965 advances to test the displays.

This procedure is used only to restore calibration, it is not meant to clear values.

Calibration Menu

Figure 28 - Calibration Parameters

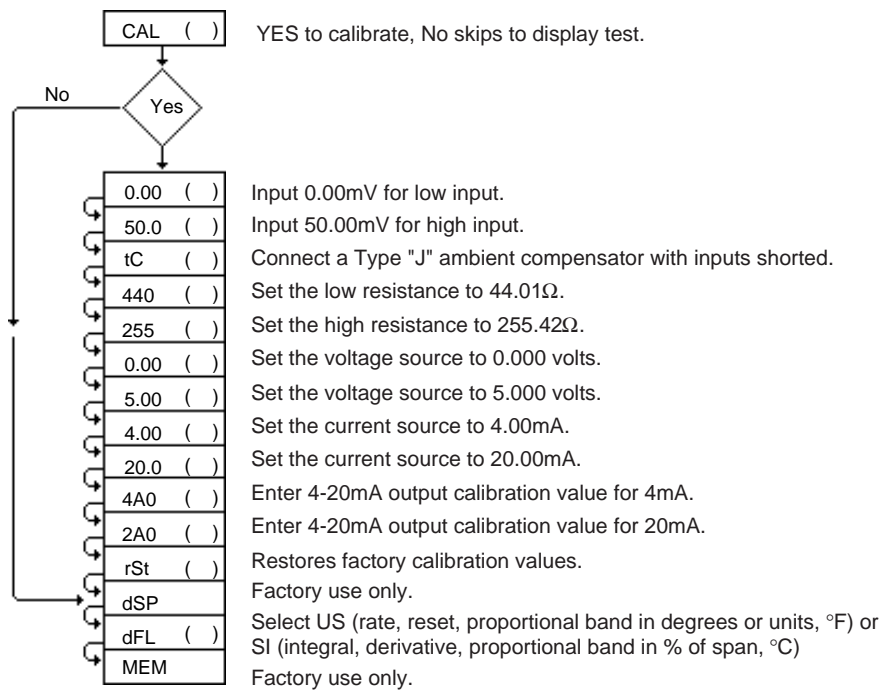

**Before attempting to calibrate,
make sure you have the proper
equipment called for in each procedure.**

**The Series 965 is calibrated and tested
before leaving the factory.**

Equipment Required

- Type "J" Reference Compensator with reference junction at 32°F/0°C, or Type "J" Thermocouple Calibrator set at 32°F/0°C.
- Precision millivolt source, 0-50mV min. range, 0.01mV resolution

Setup And Calibration

1. Connect the AC line voltage L1 and L2 to the proper terminals.
2. Connect the millivolt source to Terminal 5 Negative and Terminal 3 Positive on the Series 965 terminal strip. Use regular 20 - 24 gauge wire. Make sure the DIP switch is set for thermocouple input, see Chapter 4.
3. Apply power to the unit and allow it to warm up for 15 minutes. **After warm-up** put the unit in the CAL menu. See Figure 27 on Page 29. Select **YES**.
4. Press the A/M key twice to enter the MANUAL mode. The unit is calibrating when MN LED is on. Make sure the unit is in MANUAL mode only when you are in the correct parameters.
5. At the 0.00 prompt, enter 0.00mV from the millivolt source to the control. Allow at least 10 seconds to stabilize. Press the MODE key.
6. At the 50.0 prompt, enter 50.00mV from the millivolt source to the Series 965. Allow at least 10 seconds to stabilize. Press the MODE key.
7. At the **tC** prompt, disconnect the millivolt source, and connect the reference compensator or T/C calibrator to Terminal 5 Negative, and Terminal 3 Positive on the Series 965 terminal strip. If using a compensator, turn on and short the input wires. If using "J" calibrator, set to simulate 32°F/0°C. Allow 10 seconds for the control to stabilize. The unit will leave the CAL mode if 1 minute passes between key activations. To conclude the T/C calibration, advance the MODE key to the next prompt or exit the CAL menu. Press the A/M key twice to exit the MANUAL mode.

NOTE:
Before calibration on an installed control, make sure all data and parameters are documented. See Setup and Operation Tables, Pages 18 and 20.

NOTE:
When the MN LED is on, the unit is automatically calibrating. Your sequence is VERY important. Always move to the next parameter before changing the calibration equipment.

RTD Field Calibration Procedure

Equipment Required

- 1KΩ precision decade resistance box with 0.01Ω resolution.

Setup And Calibration

1. Connect the ac line voltage L1 and L2 to the proper terminals.
2. Connect the decade resistance box to Terminal 2, 3 and 5 on the terminal strip. Use regular 20 - 24 gauge wire of the same length and type. Make sure the DIP switch is set for RTD input, see Chapter 4.
3. Apply power to the unit and allow it to warm up for 15 minutes. **After warm-up** put the unit in the CAL menu. See Figure 27 on Page 29. Select **YES**. Press the MODE key until the **440** prompt is displayed.
4. Press the A/M key twice to enter the MANUAL mode. The unit is calibrating when the MN LED is on. Make sure the unit is in MANUAL mode **only** when you are in the correct parameters.
5. At the **440** prompt, set the decade resistance box to 44.01. Allow at least 10 seconds to stabilize. Press the MODE key to enter the calibration data. Press the A/M key twice to exit the MANUAL mode. The unit will leave the CAL mode if 1 minute passes between key activations. To conclude the RTD calibration, advance the MODE key to the next prompt or exit the CAL menu.
6. At the **255** prompt, set the decade resistance box to 255.42. Allow at least 10 seconds to stabilize. Press the MODE key.

0-5 Volt Input Field Calibration Procedure

NOTE:

Before calibration on an installed control, make sure all data and parameters are documented. See Setup and Operation Charts, Pages 18 and 20.

Equipment Required:

- Precision DC voltage source 0-5 volt minimum range with 0.001 volt resolution.

Setup and Calibration

1. Connect the AC line voltage L1 and L2 to the proper terminals on the 965.
2. Connect the voltage/current source to Terminal 3 (+) and 5 (-) on the Series 965 terminal strip. Use regular 20 - 24 gauge wire. Make sure the DIP switch is set for process input, see Chapter 4.
3. Apply power to the unit and allow it to warm up for 15 minutes. **After warm-up** put the unit in the CAL menu. See Figure 27 on Page 29. Select **YEs**. Press the MODE key until **0.00** is displayed.
4. Press A/M twice to enter the MANUAL mode. The unit is calibrating when the MN LED is on. Make sure the unit is in the MANUAL mode **only** when you are in the correct parameters. See Figure 28 on Page 30.
5. At the **0.00** parameter, set the voltage source to 0.000 volts. Allow at least 10 seconds to stabilize. Press the MODE key.
6. At the **5.00** parameter, set the voltage source to 5.000V $\overline{=}$ (VDC). Allow at least 10 seconds to stabilize. The unit leaves the CAL mode if 1 minute passes between key activations. Press A/M twice to exit the MANUAL mode. To conclude the 0-5 Volt calibration, advance the MODE key to the next prompt or exit the CAL menu.

NOTE:

When the MN LED is on, the unit is automatically calibrating. Your sequence is VERY important. Always move to the next parameter before changing the calibration equipment.

4-20mA Input Field Calibration Procedure

Equipment Required:

- Precision current source 0-20mA minimum range with 0.01mA resolution.

Setup and Calibration

1. Connect the AC line voltage L1 and L2 to the proper terminals on the 965.
2. Connect the current source to Terminal 2 (-) and 5 (+) on the Series 965 terminal strip. Use regular 20 - 24 gauge wire. Make sure the DIP switch is set for process input, see Chapter 4.
3. Apply power to the unit and allow it to warm up for 15 minutes. **After warm-up** put the unit in the CAL menu. See Figure 27 on Page 29. Select **YEs**. Press the MODE key until **4** is displayed.
4. Press A/M twice to enter the MANUAL mode. The unit is calibrating when the MN LED is on. Make sure the unit is in the MANUAL mode **only** when you are in the correct parameters. See Figure 28 on Page 30.
5. At the **4.00** parameter, set the current source to 4.00mA. Allow at least 10 seconds to stabilize. Press the MODE key.
6. At the **20.0** parameter, set the current source to 20.00mA. Allow at least 10 seconds to stabilize. The unit leaves the CAL mode if 1 minute passes between key activations. Press A/M twice to exit the MANUAL mode. To conclude, advance the MODE key to the next prompt or exit the CAL menu.

4-20mA Output Field Calibration Procedure

Equipment Required:

- 300Ω, 1/2 watt 10% resistor.
- 4 - 1/2 digit Digital Multimeter.

Setup And Calibration

1. Connect the ac line voltage L1 and L2 to the proper terminals of the 965. See Chapter 2. Set the multimeter to measure current.
2. Connect the multimeter in series with the 300Ω resistor to Terminal 9 Positive and 10 Negative on the Series 965 terminal strip. Use regular 20 - 24 gauge wire.
3. Apply power to the unit and allow it to warm up for 15 minutes. **After warm-up** put the unit in the CAL menu. Press the MODE key until the **4A0** prompt is displayed.
4. Press the A/M key twice to enter the MANUAL mode. The unit is calibrating when the MANUAL LED is on.
5. At the **4A0** prompt, the multimeter should read approximately 4mA. Allow at least 10 seconds to stabilize.
6. Use the Up-arrow/Down-arrow keys (reverse acting) to adjust the reading on the multimeter for $3.85\text{mA} \pm 0.10\text{mA}$. Press the MODE key.
7. At the **2A0** prompt, the multimeter should read approximately 20mA. Allow at least 10 seconds to stabilize. The unit will leave the CAL mode if 1 minute passes between key activations except for 4-20mA units.
8. Use the UP/DOWN keys (reverse acting) to adjust the reading on the multimeter for $20.15\text{mA} \pm 0.10\text{mA}$.
9. To conclude the 4-20mA output calibration, advance the MODE key to the next prompt or exit the CAL menu.

NOTE:

Before calibration on an installed control, make sure all data and parameters are documented. See Setup and Operation Charts, Pages 18 and 20.

NOTE:

When the MN LED is on, the unit is automatically calibrating. Your sequence is VERY important. Always move to the next parameter before changing the calibration equipment.

Alarm: A condition, generated by a controller, indicating that the process has exceeded or fallen below the set or limit point.

Alarm Silence: Disables the alarm relay output.

Anti-reset: Control feature that inhibits automatic reset action outside the proportional band.

Automatic prompts: Data entry points where a microprocessor-based control "prompts" or asks the operator/programmer for information input.

Auto-tune: Automatically tunes the Series 965 PID parameters to fit the characteristics of your particular thermal system.

Bumpless transfer: When transferring from auto to manual operation, the control output(s) will not change ("bumpless," smooth transition).

Closed loop: Control system that has a sensing device for process variable feedback.

Cold junction: Point of connection between thermocouple metals and the electronic instrument.

Cold junction compensation: Electronic means to compensate for the effective temperature at the cold junction.

Cycle time: The time necessary to complete a full on-through-off period in a time proportioning control system.

Derivative: Anticipatory action that senses the rate of change of the process, and compensates to minimize overshoot and undershoot. Also "rate."

Deviation alarm: An alarm referenced at a fixed number of degrees, plus or minus, from set point.

Default parameters: The parameters, or programmed instructions, permanently stored in microprocessor software to provide a data base.

DIN: Deutsche Industrial Norms, a widely-recognized German standard for engineering units.

Display capability: In a digital indicating instrument, the entire possible span of a particular parameter or value.

Droop: Difference in temperature between set point and stabilized process temperature.

Duty cycle: Percentage of "load on time" relative to total cycle time.

Hysteresis: In on/off control, the temperature change necessary to change the output from full on to full off.

Hunting: Oscillation or fluctuation of process temperature between set point and process variable.

Input: Process variable information being supplied to the instrument.

Integral: Control action that automatically eliminates offset, or "droop," between set point and actual process temperature. Also "reset."

Isolation: Electrical separation of sensor from high voltage circuitry. Allows for application of grounded or ungrounded sensing element.

JIS: Joint Industrial Standards. Also Japanese Industrial Standards Committee (JISC). Establishes standards on equipment and components.

Offset: Adjustment to actual input temperature and to the temperature values the Series 965 uses for display and control.

On/off control: Control of temperature about a set point by turning the output full on below set point and full off above set point in the heat mode.

Open loop: Control system with no sensory feedback.

Output: Action in response to difference between set point and process variable.

Overshoot: Condition where temperature exceeds set point due to initial power up or process changes.

P control: Proportioning control.

Parameter: A physical property whose value determines the response of an electronic control to given inputs.

PD control: Proportioning control with rate action.

PI control: Proportioning control with auto-reset.

PID control: Proportioning control with auto-reset and rate.

Process variable: Thermal system element to be regulated, such as time, temperature, relative humidity, etc.

Programmed display data: Displayed information which gives the operator/programmer the "programmed" or intended process information, i.e., intended set point, intended alarm limit, etc.

Proportional band: Span of temperature about the set point where time proportional control action takes place.

Proportioning control: See Time Proportioning Control.

Rate: Anticipatory action that senses the rate of change of temperature and compensates to minimize overshoot. Also "derivative."

Rate band: A thermal control band that defines where the rate (derivative) function begins. A Watlow rate band occurs centered on set point at one or more times the width of the proportional band.

Reference junction: Synonymous with cold junction. See "Cold junction."

Reset: Control action that automatically eliminates offset, or "droop," between set point and actual process temperature. Also "integral."

Reset windup inhibit: Synonymous with anti-reset. See "Anti-reset."

RTD: Resistance Temperature Detector. Resistive sensing device displaying resistance versus temperature characteristics. Displays positive temperature coefficient.

Set point: Intended value of the process variable.

Switching sensitivity: In on/off control, the temperature change necessary to change the output from full on to full off.

Thermal system: A regulated environment consisting of a heat source, heat transfer medium, sensing device and a process variable control instrument.

Thermocouple: Temperature sensing device that is constructed of two dissimilar metals wherein a measurable, predictable voltage is generated corresponding to temperature.

Thermocouple break protection: Fail-safe operation that assures output shutdown upon an open thermocouple condition.

Three mode control: Proportioning control with reset and rate.

Time proportioning control: Action which varies the amount of on and off time when "close" to the set point, i.e., in the proportional band. This variance is proportional to the difference between the set point and the actual process temperature. In other words, the amount of time the output relay is energized depends on the system temperature.

Triac: Solid state switching device.

Upper display data: Displayed information which gives the operator/programmer real or "actual" data, i.e., actual process temperature. See "Programmed display data."

Warm start: Start-up condition where all program information is remembered by the instrument's memory back-up protection.

Zero switching: Action that provides output switching only at the zero-voltage, crossing points of the ac line.

Index

A

Alarms 24
 Wiring 11
Appendix 27
A/M key 13
Automatic Operation 13, 23
Auto-tuning 21

B

Bumpless transfer 23

C

Calibration 29
Calibration Offset 20

D

DC Output 1 10
DC Output 2 11
Declaration of Conformity 40
Default Parameters
 Operation 20
 Setup 18
Dimensions
 Faceplate 5
 Panel Cutout 5
 Sideview 5
DIP Switches 14
Displays 13, 17
Down-arrow key 13

E

Eliminate Noise 28
Entering the Setup Menu 15
Error Codes 25

F, G

General Description 4
Glossary 34

H

High Voltage Wiring 7
Hysteresis 17

I

Input
 Wiring 8
 DIP Switch 14
 Ranges 18
Input Installation 5

J, K

Keys 13

L

L1 & L2 Keys 13
Ladder Wiring Diagram, System 12
Lock Parameter 16
Low Voltage Wiring 7
Lower Display 13

M

M/N Key 13
Manual Operation 13, 23
Manual Tuning 22
Mechanical Relay, 5 Amp
 Output 1 Wiring 10
 Output 2 Wiring 11
MODE key 13
Model Number 39

N

Noise
 Eliminating 28
 Sources 27
 Decreasing Sensitivity 27

O

Operation Parameters 19
Output Wiring
 5A Mechanical Relay 10, 11
 4-20mA 10
 DC (Open Collector) 10, 11
 Solid State Relay w/o Supp. 10, 11
Overview of the Series 965 4

P

Power Limiting 17
Power Wiring 7
Process Input 8, 9
Process Output 10

Q

Quick Reference Sheet 41

R

Ramping 17
Rate 17
Restoring Calibration 30
Returns 37
RTD Calibration 31
RTD Sensor Wiring 9

S

Sensor Wiring 8
Series 965 Input And Output Overview 4
Setup Menu and Parameters 15
Specifications 38
System Wiring Example 12

T

Thermocouple Break Protection 7, 8, 16, 23
Thermocouple Calibration 31
Thermocouple Sensor Wiring 8
Tuning 21

U, V, W

Up-arrow key 13
Upper Display 13
Warranty 37

Warranty

The Watlow Series 965 is warranted to be free of defects in material and workmanship for 36 months after delivery to the first purchaser for use, providing that the units have not been misapplied. Since Watlow has no control over their use, and sometimes misuse, we cannot guarantee against failure. Watlow's obligations hereunder, at Watlow's option, are limited to replacement, repair or refund of purchase price, and parts which upon examination prove to be defective within the warranty period specified. This warranty does not apply to damage resulting from transportation, alteration, misuse, or abuse.

Returns

1. Call Watlow Customer Service, (507)454-5300, for a Return Material Authorization (RMA) number before returning any item for repair. We need this information:
 - Ship to address
 - Bill to address
 - Contact name
 - Phone number
 - Ship via
 - Your P.O. number
 - Symptoms and/or special instructions
 - Name and phone number of person returning the material.
2. Prior approval and an RMA number, from the Customer Service Department, is needed when returning any unused product for credit. Make sure the RMA number is on the outside of the carton, and on all paperwork returned. Ship on a Freight Prepaid basis.
3. After we receive your return, we will examine it and determine the cause for your action.
4. In cases of manufacturing defect, we will enter a repair order, replacement order, or issue credit for material. A 20 percent restocking charge is applied for all returned stock controls and accessories.
5. If the unit is unrepairable, it will be returned to you with a letter of explanation. Repair costs will not exceed 50 percent of the original cost.

Watlow Controls

Watlow Controls is a division of Watlow Electric Mfg. Co., St. Louis, MO, a manufacturer of industrial electric heating products, since 1922. Watlow begins with a full set of specifications and completes an industrial product that is manufactured totally in-house, in the U.S.A. Watlow products include electric heaters, sensors, controls and switching devices. The Winona operation has been designing solid state electronic control devices since 1962, and has earned the reputation as an excellent supplier to original equipment manufacturers. These OEMs depend upon Watlow Controls to provide compatibly engineered controls which they can incorporate into their products with confidence. Watlow Controls resides in a 100,000 square foot marketing, engineering and manufacturing facility in Winona, Minnesota.

Specifications

Specifications—(1460)

Control Mode

- Microprocessor-based, user selectable control modes
- Single input, dual output
- 2.5Hz Input Sampling Rate
- 1Hz Display Update Rate
- Ramp to set point: 0 to 9999 degrees or units per hour
- Heat and cool auto-tune

Agency Approvals

- UL and C-UL recognized, File #E43684, UL873
- CE approved
 - 89/336/EEC Electromagnetic Compatibility Directive
 - EN 50081-2: 1994 Emissions
 - EN 50082-2: 1995 Immunity
 - 73/23/EEC Low Voltage Directive
 - EN 61010-1: 1993 Safety

- NEMA 4X₂, I.P. 65 rating

Operator Interface

- Sealed membrane front panel
- Dual, four-digit red or green displays
- MODE, Up-arrow, Down-arrow, and AUTO/ MANUAL keys
- User selectable screen display

Accuracy

- Calibration accuracy and sensor conformity: $\pm 0.1\%$ of span, ± 1 LSD @ 77°F ± 5 °F (25°C ± 3 °C) ambient and rated line voltage
- Accuracy span: 1000°F (540°C) minimum
- Temperature stability: ± 0.2 °F/°F (± 0.2 °C/°C) rise in ambient maximum
- Voltage stability: $\pm 0.01\%$ of span per percent of rated line voltage

Sensors/Inputs

- Thermocouple, grounded or ungrounded sensors
- RTD 2- or 3-wire, platinum, 100Ω @ 0°C calibration to DIN curve (0.00385Ω/Ω/°C) or JIS curve (0.003916Ω/Ω/°C); user selectable
- Process, 4-20mA @ 5Ω, or 0-5V_{dc} @ 10kΩ input impedance
- Sensor break protection de-energizes control output to protect system or selectable bumpless transfer to manual operation
- °F or °C or process units display, user selectable

Input Range

Specified temperature ranges represent the controller's operational span.

• Thermocouple

Type J	32	to	1382°F
	(0	to	750°C)
Type K	-328	to	2282°F
	(-200	to	1250°C)
Type N	32	to	2282°F
	(0	to	1250°C)
Type S	32	to	2642°F
	(0	to	1450°C)
Type T	-328	to	662°F
	(-200	to	350°C)

• RTD Resolution (DIN or JIS)

1°	-328	to	1292°F
	(-200	to	700°C)
0.1°	-199.9	to	999.9°F
	(-128.8	to	537.7°C)

• Process

4-20mA @ 5Ω, or -999 to 9999 units
0-5V_{dc} @ 10kΩ, or -999 to 9999 units

Output 1 (Heating or Cooling)

- Electromechanical relay₁, Form C, 5A @ 120/240V~ (ac) maximum, without contact suppression, rated resistive load, 5A @ 30V_{dc} (dc)₃.
- Switched dc signal provides a non-isolated minimum turn on voltage of 3V_{dc} into a minimum 500Ω load; maximum on voltage not greater than 12V_{dc} into an infinite load.
- 4-20mA reverse or direct acting, non-isolated 0 to 800Ω load.
- Solid-state relay₃, Form A, 0.5A @ 24V~ (ac) min., 264V~ (ac) max., opto-isolated burst fire switched, without contact suppression. Off-state output impedance is 31MΩ.

Output 2 (Heat, Cool or Alarm)

- Electromechanical relay₁, Form C, 5A @ 120/240V~ (ac) maximum, without contact suppression, rated resistive load, 5A @ 30V_{dc} (dc)₃.
- Switched dc signal provides a non-isolated minimum turn on voltage of 3V_{dc} into a minimum 500Ω load; maximum on voltage not greater than 12V_{dc} into an infinite load.
- Solid-state relay₃, Form A, 0.5A @ 24V~ (ac) min., 264V~ (ac) max., opto-isolated burst fire switched, without contact suppression. Off-state output impedance is 31MΩ.
- Alarm output can be latching or non-latching, and process or deviation with separate high and low values. Alarm silencing (inhibit) on power up.

Output Configurations

• Output 1

- User selectable as: on/off: P, PI, PD, PID, heat or cool action
- Adjustable switching differential: 1 to 99°F (1 to 55°C)
- Proportional band: 0 (off) or 1 to 999°F (0 to 555°C) or 0.0 to 999.9 units

Integral: 0 (off) or 0.1 to 99.9 minutes per repeat

Reset: 0 (off) or 0.01 to 9.99 repeats per minute

Rate/derivative: 0 (off) or 0.01 to 9.99 minutes

Cycle time: 0.1 to 999.9 seconds

• Output 2

- User selectable as: Control with action opposite that of Output 1 (heating or cooling)

- Process or deviation alarm with flashing alarm message
- Process or deviation alarm without alarm message
- Alarm with separate high and low set points
- Hysteresis: 1 to 9999° or units switching differential

Line Voltage/Power

- 100-240V~ (ac), +10%, -15%; (85-264V~ [ac]) 50/60Hz, $\pm 5\%$
- 12-24V_{dc} (ac/dc), +10%, -15%; (10-26V_{dc} [ac/dc]) 50/60Hz, $\pm 5\%$
- Fused internally (factory replaceable only) Slo-Blo® type (time-lag):
 - 1A, 250V for high voltage versions
 - 2A, 250V for low voltage versions
- Power consumption 5VA maximum
- Data retention upon power failure via non-volatile memory

Operating Environment

- 32 to 149°F (0 to 65°C)
- 0 to 90% RH, non-condensing

Storage Temperature

- -40° to 185°F (-40° to 85°C)

Terminals

- #6 compression universal head screw terminals, accepts 20-14 gauge wire

Controller Weight

- 0.4 lb (0.2 kg)

Shipping Weight

- 0.75 lb (0.34 kg)

Dimensions

- Compact 1/16 DIN size and NEMA 4X₂, (I.P. 65) front panel make the Series 965 easy to apply and maintain in a wide variety of applications. Unique mounting bezel, gasket and collar make installation a snap.

Overall	Height:	2.1 inches	(55 mm)
	Width:	2.1 inches	(55 mm)
	Depth:	4.7 inches	(120 mm)
Bezel	Height:	2.1 inches	(55 mm)
	Width:	2.1 inches	(55 mm)
	Depth:	0.6 inches	(15 mm)
Chassis	Height:	1.8 inches	(45 mm)
	Width:	1.8 inches	(45 mm)
	Depth:	4.1 inches	(105 mm)

¹ Electromechanical relays warranted for 100,000 closures only. Solid-state switching devices recommended for applications requiring fast cycle times or extended service life.

² To effect NEMA 4X (I.P. 65) rating requires a minimum mounting panel thickness of 0.06inch (1.5 mm) and surface finish not rougher than 0.000032 inch (0.000812 mm).

³ Switching inductive loads (relay coils, etc.) requires using an RC suppressor.

Series 965 Model Number Information

Ordering Information—W965-XMNN Rev A00

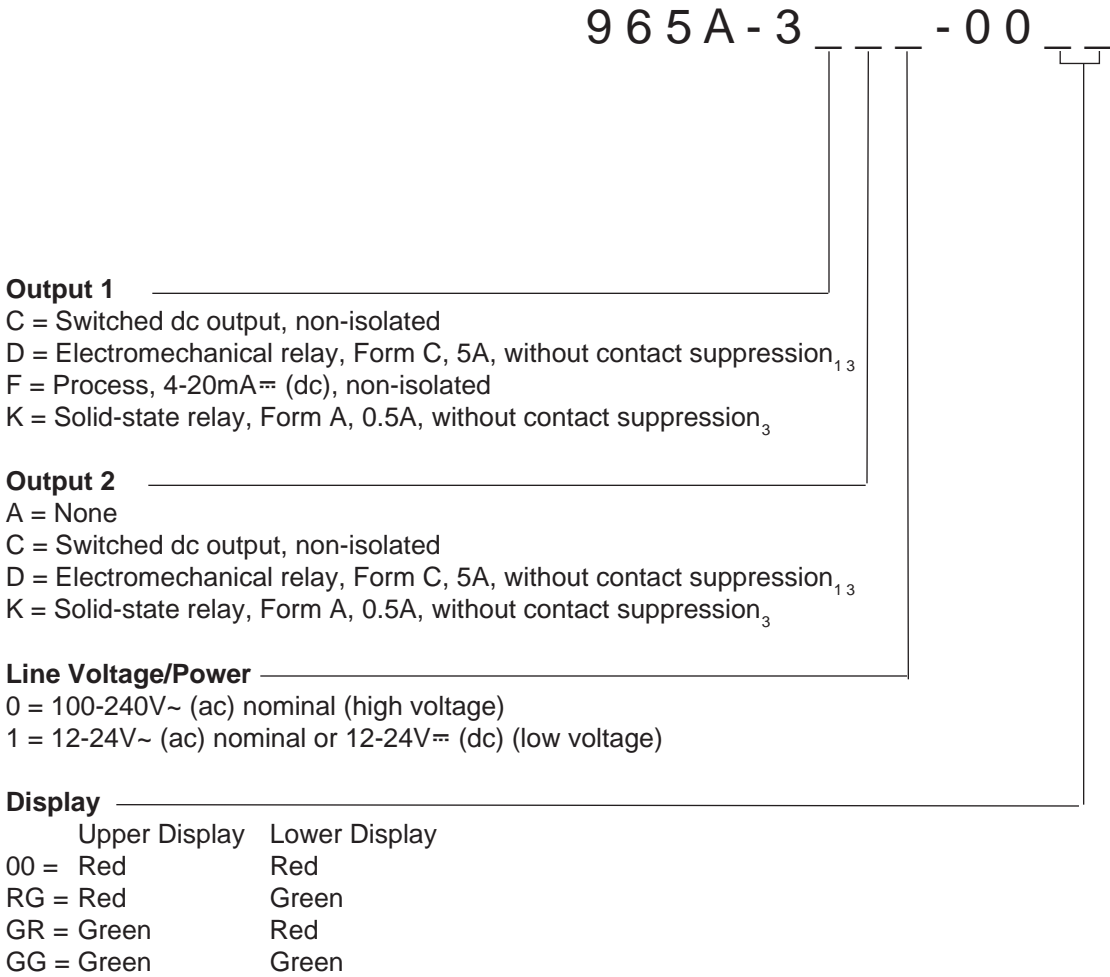

* Note: If this output will drive a solenoid, MDR, contactor or other inductive device, order a Quencharc™ (0804-0147-0000) for output protection. See Chapter 2 for wiring.

- Spare Parts**
- Mounting collar 0822-0395-0000
 - Case gasket 0830-0402-0002
 - Protective terminal cover 0822-0426-0001
 - Internal bezel gasket 0830-0402-0001
 - Quencharc™ RC 0804-0147-0000
 suppressor

Conformity

Put Declaration of Conformity on this page.

Series 965 Quick Reference

Use this page as a quick reference for the Series 965. Tear along the perforation.

Keys & Displays

Upper Display: Red or green, LED display, indicating either process actual temperature, the operating parameter values, or an open sensor.

Lower Display: Red or green, four digit LED display, indicating the set point, output value, parameters for data in the upper display, or error and alarm codes.



L1: When lit it indicates Output 1 is energized.

L2: When lit it indicates when Output 2 is active. This output can be configured as a control or alarm output.

MN: Lit when in manual operation. Press A/M twice to enter Automatic. When blinking, press A/M to toggle between Auto and Manual. After 5 seconds without key activations it returns to its previous state.

MODE Key: Steps the control through the operating menu, also, in the Auto mode, new data is self entering in 5 seconds.

Up-arrow Key: Increases the value of the displayed parameter. New data is self entering in 5 seconds.

Down-arrow Key: Decreases the value of the displayed parameter. New data is self entering in 5 seconds.

A/M Key: Press once to clear latched alarms and toggles between Auto and Manual. If pressed within 5 seconds it changes from Auto to Manual or vice versa. While in Manual, percent power is in the lower display.

Up-arrow/Down-arrow Keys: When pressed simultaneously for 3 seconds, the Setup Menu appears displaying the LOC parameter. Continue to press the UP/DOWN keys, and the Calibration menu appears.

Alarms

Process Alarm sets an absolute temperature. When the process exceeds that absolute temperature limit an alarm occurs. The process alarm set points may be independently set high and low. Under the Setup menu, select the type of alarm output with the Ot2 parameter.
PrA = Process alarm
Pr = Process alarm with no alarm message displayed

Deviation Alarm: Alerts the operator when the process strays too far from set point. The operator can enter independent high and low alarm settings. The reference for a deviation alarm is set point. Any change in set point causes a corresponding shift in the deviation alarm. Under the Setup menu, select the type of alarm output with the Ot2 parameter.
dEA = Deviation alarm
dE = Deviation alarm with no alarm message displayed

Alarm Silencing is available with the deviation alarm. When SIL is selected as "on," the operator must manually disable the alarm by pressing the A/M key once on initial power up (in either the latching or non-latching mode). Alarm silencing disables the alarm output relay. However, the L2 LED (also the lower display when Ot2 = dEA) shows an alarm condition until the process value is within the "safe" region of

the deviation alarm band. Once the process value crosses into the "safe" region, both a latching or a non-latching alarm is ready. Any future deviation outside this safe band triggers an alarm. Both alarms can be latching or non-latching. When the alarm condition is removed a non-latching alarm automatically clears the alarm output. You must manually clear a latching alarm before it will disappear.



Press once to clear a latched and corrected alarm.



Flashing LO or HI in the lower display indicates an alarm when Ot2 = PrA or dEA. The lower display alternately shows information from the current parameter and a LO or HI alarm message at one second intervals. The alarm output is de-energized, L2 is lit.

To clear an alarm...

- First correct the alarm condition, then...
 - **If the alarm is latching...**
Clear it manually; press the A/M key once as soon as the process temperature is inside the HSA parameter alarm limit.
 - **If the alarm is non-latching...**
The alarm clears itself automatically as soon as the process temperature is inside the HSA parameter alarm limit.

Error Codes

Four dashes, "- - - -" or a negative number, in the upper display indicate a Series 965 error. The error code is visible in the lower display.



Er 2 - Sensor underrange error (For RTD units only)

The sensor input generated a value lower than the allowable signal range, or the A/D circuitry malfunctioned. Enter a valid input. Make sure the In parameter matches your sensor and DIP switch setting. Refer to the table below for the appropriate input type and range.

Er 4 - Configuration error

The unit's microprocessor is faulty; call the factory.

Er 5 - Non volatile checksum error

The nonvolatile memory checksum discovered a checksum error. Unless a momentary power interruption occurred while the unit was storing data, the nonvolatile memory is bad. Call the factory.

Er 6 - A/D underflow error

The A/D circuit is underrange. An open or reversed polarity sensor is the most likely cause. Check the sensor; if the connection is good and functions properly, call the factory. The A/D underrange voltage is too low to convert an A/D signal. Make sure the In parameter matches your sensor and the DIP switches are set accordingly.

Er 7 - A/D overflow error

The A/D circuit is overrange. An open or reversed polarity sensor is the most likely cause. Check the sensor; if the connection is good and the sensor functions properly, call the factory. The A/D overrange voltage is too high to convert an A/D signal. Make sure the In parameter matches your sensor and the DIP switches are set accordingly.

Entering the Setup Menu



The Setup Menu displays the parameters that configure the Series 965's features to your application.

Enter the Setup menu by pressing the Up-arrow/Down-arrow keys simultaneously for 3 seconds. The lower display shows the LOC parameter, and the upper display shows its current level. All keys are inactive until you release both keys. You can reach the LOC parameter from anywhere.

You will not see all parameters in these menus depending on your unit's configuration and model number.

Setup Menu

Do not enter any values here; make photocopies instead.

Parameters	Value	Range	Factory Default	Appears If:
LOC		0 through 4	0	
In		J, K (appears as H), t, n, S, rtd, rt.d, 0-5, 420	J	DIP switch selectable
dEC		0, 0.0, 0.00	0	In = 0-5 or 420
C_F		C or F	C	dFL = SI or In = T/C or RTD dFL = US or In = T/C or RTD
rL		rL to rH	Input dependent	
rH		rH to rL	Input dependent	
Ot1		ht or CL	ht	
HSC		1 to 99, 0.1 - 9.9, 0.01 - 0.99	3, 0.3, 0.03°F	
Ot2		Con = Control PrA = Process alarm Pr = Process with no alarm message dEA = Deviation alarm dE = Deviation with no alarm message no = None	Con	
HSA		1 to 9999, 0.1 - 999.9, 0.01 - 99.99	3, 0.3, 0.03°F	Ot2 ≠ Con or no
LAt		LAt or nLA	nLA	Ot2 ≠ Con or no
SIL		On or OFF	OFF	Ot2 = dEA or dE
rtd		JIS or din	din	In = rtd or rt.d
rP		Str = Ramping on power up on = Ramping to set point at all times OFF = None	OFF	
rt		0 to 9999	100°/hr	rP ≠ OFF
PL		0 to 100	100	
dSP		nor = Normal SEt = Set Point (lower display only) Pro = Process (upper display only)	nor	



LOC ()	User lock out
In ()	Input type
dEC ()	Decimal place
C_F ()	Celsius_Fahrenheit
rL ()	Range low
rH ()	Range high
Ot1 ()	Output 1
HSC ()	Control hysteresis
Ot2 ()	Output 2
HSA ()	Output 2 hysteresis
LAt ()	Latching for alarm
SIL ()	Silence alarm
rtd ()	RTD calibration curve
rP ()	Ramp function
rt ()	Ramp rate
PL ()	Power limiting
dSP ()	Display
75	

Operation Menu

Do not enter any values here; make photocopies instead.

Parameters	Value	Range	Factory Default	Appears If:
Pb1		0 to 999°F/0 to 555°C/0 to 999 Units 0 to 99.9°F/0 to 55.5°C/0 TO 99.9 UNITS 0.0 to 999.9% of span 0 = ON/OFF control, HSC = Switching diff.	25°F 2.5°F 3% / .3%	dFL = US dFL = SI
rE1		0.00 to 9.99 repeats/minute / 0.00 = No reset	0.00 repeats/minute	Pb1 ≠ 0 or dFL = US
It1		00.0 to 99.9 minutes/repeat / 0.00 = No integral	00.0 minutes/repeat	Pb1 ≠ 0 or dFL = SI
rA1		0.00 to 9.99 minutes / 0.00 = No rate	0.00 minutes	Pb1 ≠ 0 or dFL = US
dE1		0.00 to 9.99 minutes / 0.00 = No derivative	0.00 minutes	Pb1 ≠ 0 or dFL is SI
Ct1		0.1 to 999.9 seconds	5.0 seconds	Pb1 ≠ 0 or Output 1 ≠ 420
Pb2		1 to 999°F/0 to 555°C/0 to 999 Units 1 to 99.9°F/0 to 55.5°C/0 to 99.9 Units 0.1 to 999.9% of span	25°F 2.5°F 3% / .3%	dFL = SI, Ot2 = Con, Pb1 ≠ 0
rE2		0.00 to 9.99 repeats/minute / 0.00 = No reset	0.00 repeats/minute	dFL = US, Ot2 = Con, Pb1 ≠ 0
It2		00.0 to 99.9 minutes/repeat / 0.00 = No integral	00.0 minutes/repeat	dFL = SI, Ot2 = Con, Pb1 ≠ 0
rA2		0.00 to 9.99 minutes / 0.00 = No rate	0.00 minutes	dFL = US, Ot2 = Con, Pb1 ≠ 0
dE2		0.00 to 9.99 minutes / 0.00 = No derivative	0.00 minutes	dFL = SI, Ot2 = Con, Pb1 ≠ 0
Ct2		0.1 to 999.9 seconds	5.0 seconds	Ot2 = Con, Pb1 ≠ 0
ALO		-999° to 0 rL to AHl	-999° rL	Ot2 = dE or dEA Ot2 = Pr or PrA
AHl		0 to 999° ALO to rH	999° rH	Ot2 = dE or dEA Ot2 = Pr or PrA
CAL		± 18°F/±10°C/±18 Units	0	
AUt		0 = off, 1 = slow, 2 = medium, 3 = fast	0	



75	Control Set Point
Pb1 ()	Proportional band 1
rE1/It1 ()	Reset 1/Integral 1
rA1/dE1 ()	Rate 1/Derivative 1
Ct1 ()	Cycle time 1
Pb2 ()	Proportional band 2
rE2/It2 ()	Reset 2/Integral 2
rA2/dE2 ()	Rate 2/Derivative 2
Ct2 ()	Cycle time 2
ALO ()	Alarm low
AHl ()	Alarm high
CAL ()	Calibration offset
AUt ()	Auto-tune

Watlow Series 965 User's Manual

Watlow Controls, 1241 Bundy Blvd., P.O. Box 5580, Winona, MN 55987-5580, Phone: 507/454-5300, Fax: 507/452-4507