

DIN-A-MITE® Style A

Solid-State Power Controller

User's Manual



Warranty

The DIN-A-MITE is warranted to be free of defects in material and workmanship for 36 months after delivery to the first purchaser for use, providing that the units have not been misapplied. Since Watlow has no control over their use, and sometimes misuse, we cannot guarantee against failure. Watlow's obligations hereunder, at Watlow's option, are limited to replacement, repair, or refund of purchase price, and parts which upon examination prove to be defective within the warranty period specified. This warranty does not apply to damage resulting from transportation, alteration, misuse, abuse, or improper fusing.

Returns

- Call Customer Service: (507) 454-5300, or fax: (507) 452-4507, for a Return Material Authorization (RMA) number before returning any item for repair.
- Make sure the RMA number is on the outside of the carton, and on all paperwork returned. Ship on a freight prepaid basis.
- A restocking charge of 20% of the net price applies for all returned stock controls and accessories in like new condition and within 120 days after shipment. Non-stock and modified stock items are not returnable.
- If the unit is unrepairable, it will be returned to you with a letter of explanation. Repair costs will not exceed 50% of the original cost.

Technical Assistance

If you encounter a problem with your Watlow controller, review your configuration information to verify that your selections are consistent with your application: inputs; outputs; alarms; limits; etc. If the problem persists after checking the configuration of the controller, you can get technical assistance from your local Watlow representative, or in the U.S., dial +1 (507) 494-5656. For technical support, ask for an Applications Engineer.

Please have the following information available when calling:

- Complete model number
- All configuration information
- User's Manual

The DIN-A-MITE Style A User's Manual is copyrighted by Watlow, Inc., © September 2013, with all rights reserved.



1241 Bundy Boulevard, Winona, Minnesota USA 55987

Phone: +1 (507) 454-5300, Fax: +1 (507) 452-4507 <http://www.watlow.com>

Please consult this user manual when you place your new DIN-A-MITE in service. It contains all the necessary information to mount and wire the product into the application. This manual also contains all the user-pertinent specifications and semiconductor fusing recommendations. Please refer to national and local electrical code safety guidelines whenever you install electrical equipment.

This DIN-A-MITE product is capable of switching up to 18 A single phase at 600V~ (ac), depending on the model selected at 50°C. (See the output rating curve in the specifications section.) The DIN-A-MITE is electrically touch-safe, and includes DIN (Deutsche Industrial Norm) rail or standard back panel mounting. UL® 508-listed, C-UL®, and CE-approved (see Declaration of Conformity [filter required]).



Unit Dimensions

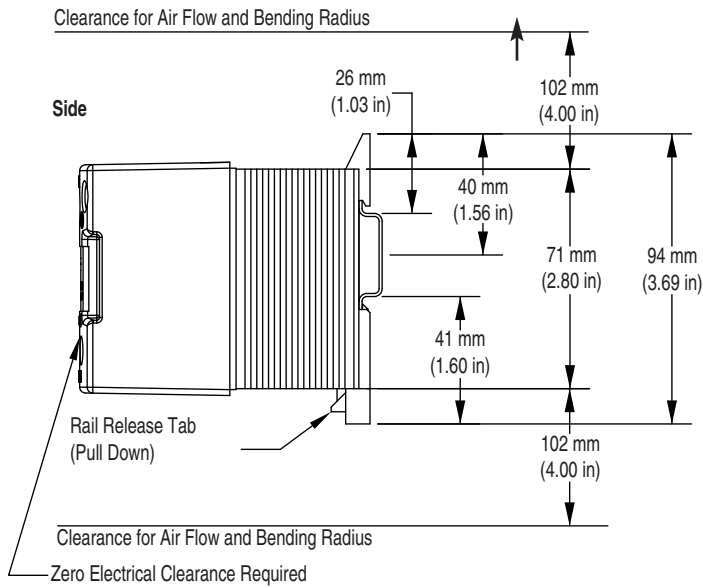
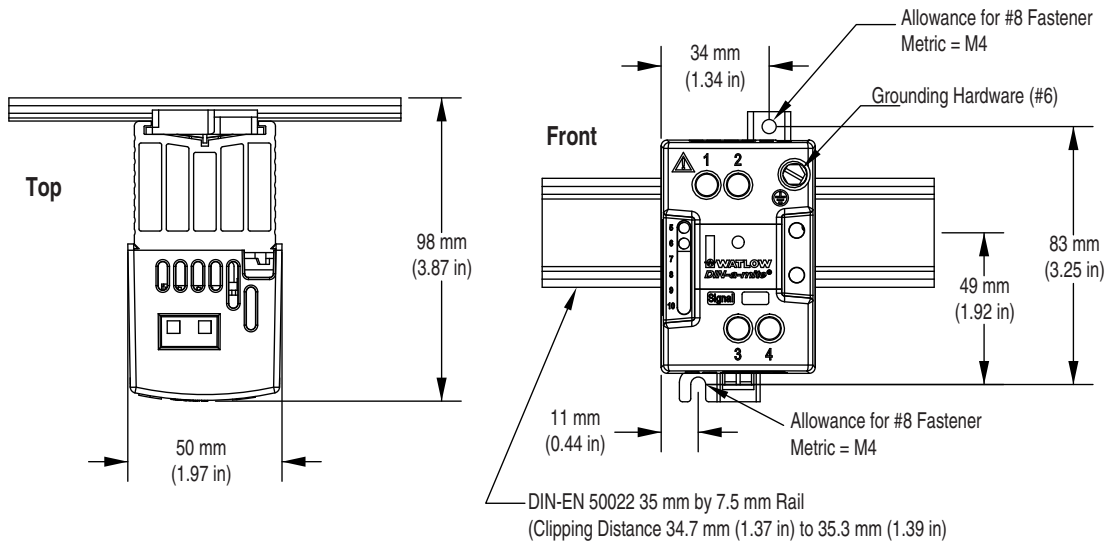

! Mount the cooling fins vertically. Failure to do so may cause premature unit failure.



Mounting and Dismounting

To mount:

1. Push the unit in and down to catch the rail hook on top of the rail.
2. Rotate the bottom of the unit in toward the rail.
3. The rail clasp will audibly “snap” into place. If the DIN-A-MITE does not snap into place, check to see if the rail is bent.
4. Mount the cooling fins vertically.

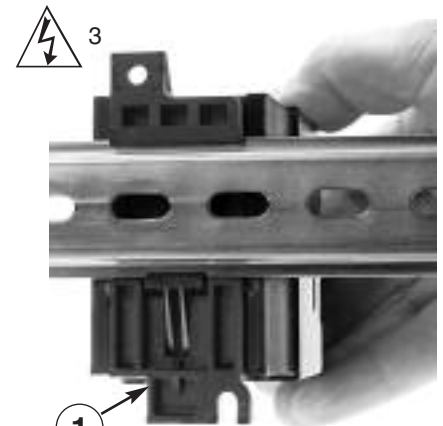
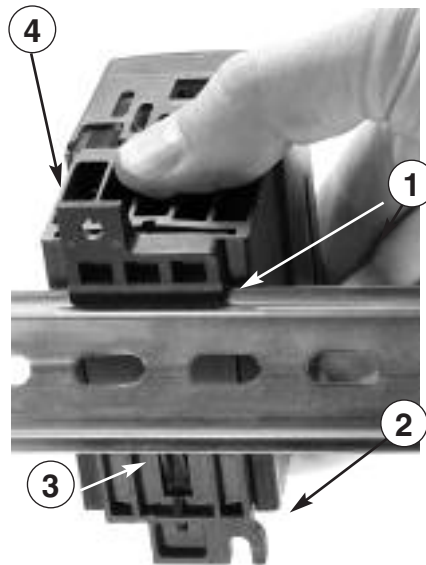

To dismount:

1. Press down on the release tab while rotating the unit up and away from the rail.

Single-phase Output and Input Wiring

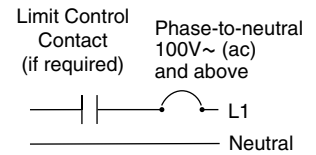
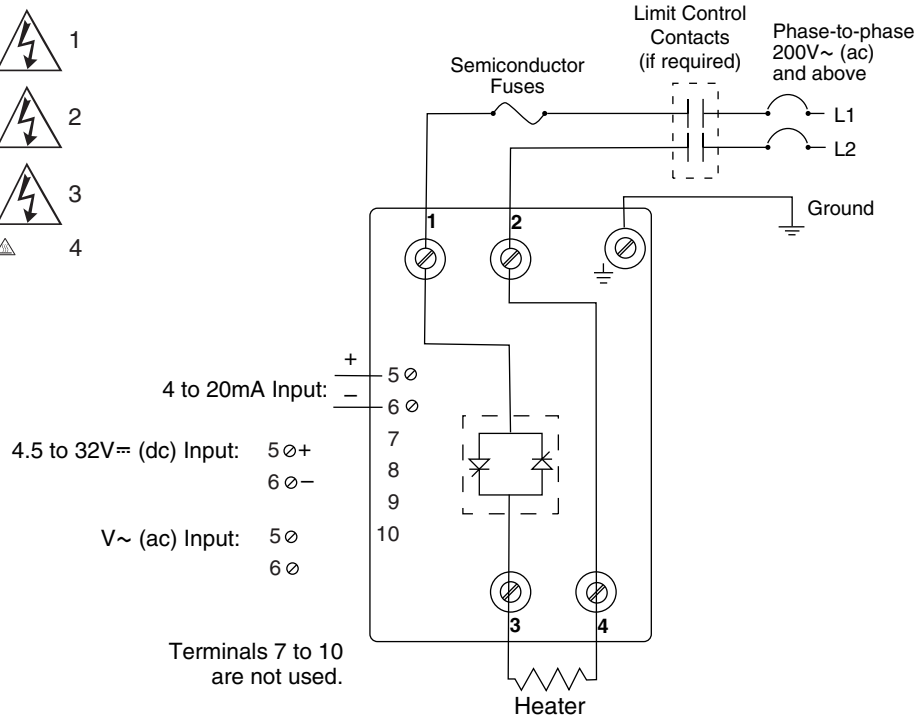

NOTE:

Grounding

- Use a grounding conductor terminal plate (fork terminal) having upturned lugs or the equivalent to hold the wire in position. Maximum 6 mm² (10 AWG) wire.

Fusing

- Recommended fusing options (see page 6) to meet 200KA SCCR, type 1 and 2 approved. All other fuse and SCR combinations are defaulted to 5KA SCCR per UL508A and NEC guidelines.

Torque Guidelines

- Properly torque line and load terminals to 1.4 Nm (12 in-lb).
- Retorque after 48 hours to minimize wire cold flow.
- Retorque line and load terminals every 3 to 6 months.



WARNINGS:



- 1 WARNING:** Use National Electric (NEC) or other country-specific standard wiring practices to install and operate the DIN-A-MITE. Failure to do so may result in damage to equipment and property, and/or injury or loss of life.



- 2 WARNING:** Wiring examples show L2 in phase-to-phase, 200 V~ (ac) and above configuration. In phase-to-neutral, 100 V~ (ac) and above applications, L2 is neutral and must not be fused or switched. Failure to follow this guideline could result in personal injury or death.



- 3 WARNING:** Only authorized and qualified personnel should be allowed to install and perform preventive and corrective maintenance on this unit. Failure to do so could result in damage to equipment, and personal injury or death.



- 4 WARNING:** Hot surface, do not touch the heat sink. Failure to follow this guideline could result in personal injury.

System Wiring Example

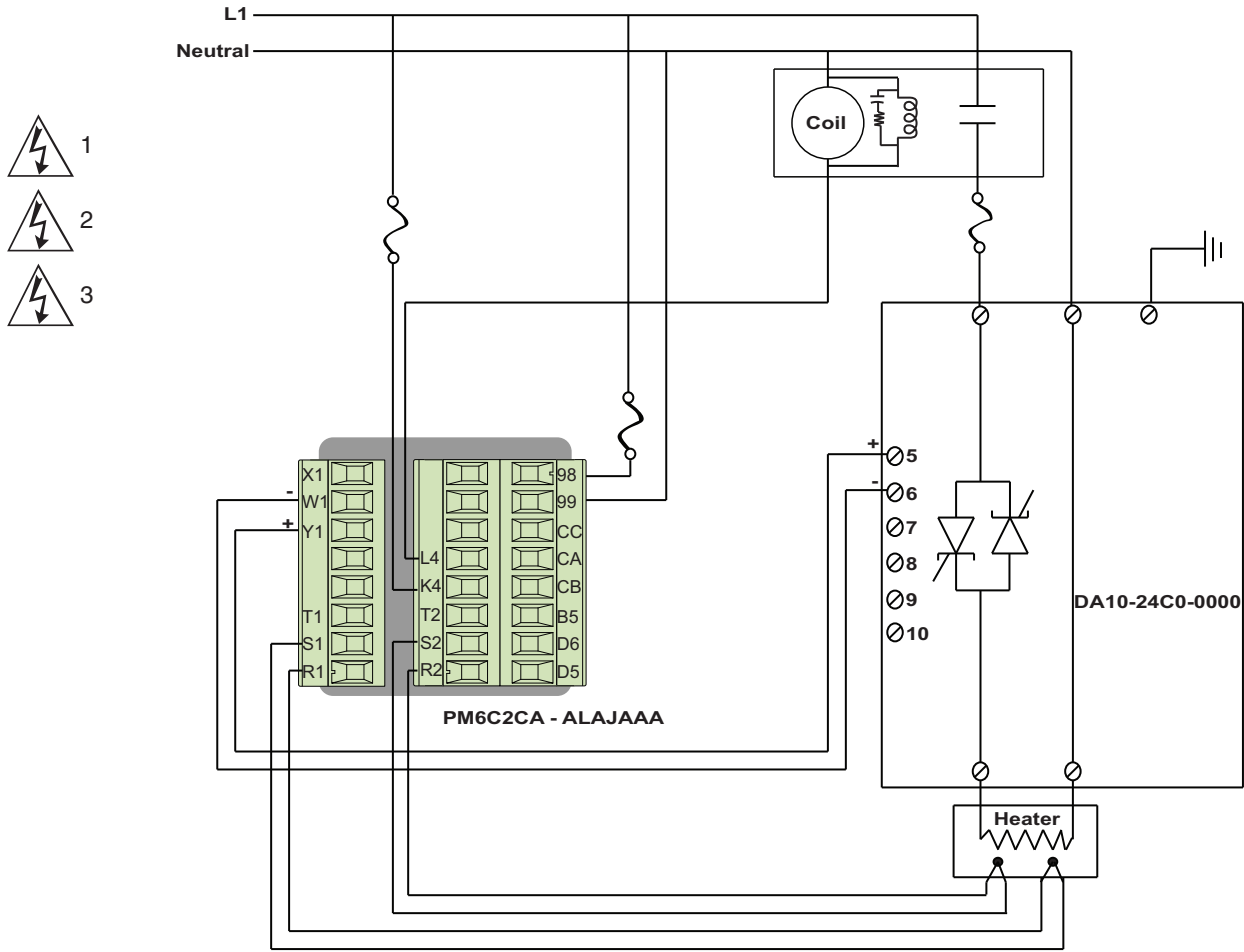

Required External EMI Filters for DIN-A-MITE with More than 6 A Loads

An external EMI filter must be used in conjunction with the DIN-A-MITE for loads in excess of six amperes (6A) at 150 to 250 kHz. Without a filter applied, the DIN-A-MITE does not comply with the conducted emissions standard for loads above 6A at 150 to 250 KHz.

Watlow has verified that two types of filters will suppress electromagnetic interference (EMI) created by the DIN-A-MITE power controller to within the CE requirements.

A tank filter supplied by Crydom or Watlow, installed across the power lines, suppresses EMI on the power lines. See figure below. See Table 1 for the correct filter.

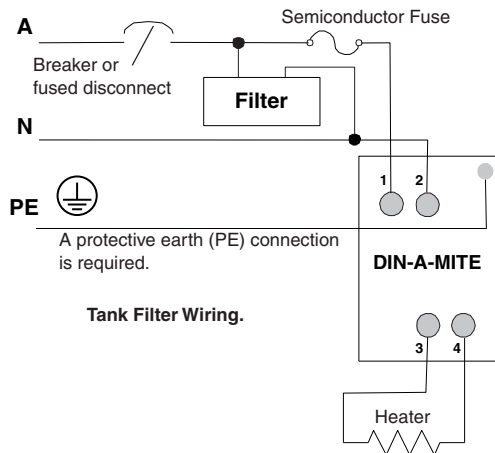

Description	Crydom Filter	Watlow Filter
Single-phase, 230V~ (ac)	1F25	14-0019

Table 1— DIN-A-MITE EMI Filters.

! WARNING:

The tank filters specified may suppress desirable communications carried on power lines in the 150 to 250 kHz region. The filters may suppress carrier current such as that used for infant monitors and medical alert systems. Verify that suppressed carrier current or other desirable communications on power lines creates no hazard to people or property. Failure to observe this warning could result in damage to property, and injury or death for personnel.

⚡ WARNING:

All filter installation and wiring must be performed by qualified personnel, and conform to local and national electrical codes. Failure to observe this warning could result in damage to property, and injury or death for personnel.

Specifications

Operator Interface

- Command signal input
- Input indicator LED

Amperage

- Single-phase, 18 A output maximum at 50°C (122°F) into a resistive load. See the output rating curve.
- Maximum I²t for fusing: 4,000 A²sec
- Holding current: 100 mA minimum
- Latching current: 200 mA minimum
- Power dissipation: 1.2 watts per amp switched
- 200KA SCCR with recommended fusing

Line Voltage

- 24 to 48V~ (ac) units: 20V~ (ac) minimum to 53V~ (ac) maximum
- 120 to 240V~ (ac) units: 48V~ (ac) minimum to 265 V~ (ac) maximum
- 277 to 600V~ (ac) units: 85V~ (ac) minimum to 660V~ (ac) maximum
- Off-state leakage: 1 mA at 25°C (77°F) maximum
- 50/60 Hz. independent

Control Mode, Zero Cross

- Input Control Signal Type C: V= (dc) input contactor. To increase service life, the cycle time should be less than 3 seconds.
- Input Control Signal Type K: V~ (ac) input contactor. To increase service life, the cycle time should be less than 3 seconds.
- Input Control Signal Type F: 4 to 20 mA= (dc) proportional variable time base control.

Input Command Signal

- **AC contactor**
24 V~ ±10%, 120V~ +10%/-25%, 240V~ (ac) +10%/-25% @ 25 mA maximum per controlled leg
- Do not use the DIN-A-MITE Vac-input models with a temperature controller that includes an RC snubber circuit across its output. Remove the RC snubber circuit before placing the DIN-A-MITE into service.
- **DC Contactor**
4.5 to 32V= (dc): maximum current @ 4.5V= (dc) is 8 mA per leg.
- **Loop powered linear current**
4 to 20 mA= (dc): loop-powered. Input Type F0 option only. (Requires current source with 6.2V= (dc) available. No more than three DIN-A-MITE inputs can be connected in series.)

Agency Approvals

- UL[®] 508-listed and C-UL[®] File E73741
- CE with proper filter:
EN 61326 Industrial Immunity Class A Emissions
EN 50178 Safety requirements

Input Terminals

- Compression: Will accept 0.2 to 1.5 mm² (24 to 16 AWG) wire
- Torque to 0.5 Nm (4.4 in-lb) maximum with a 3.5 mm (1/8 in) blade screwdriver
- Strip 5.5 mm (0.22 in)

Line and Load Terminals

- Compression: Will accept 0.75 to 10 mm² (18 to 8 AWG) wire
- Torque to 1.4 Nm (12 in-lb) with a 6.4 mm (1/4 in) blade screwdriver, or Type 1A #2 Pozi driver .
- Retorque after 48 hours to minimize wire cold flow.
- Retorque line and load terminals every 3 to 6 months.
- Strip 6.4 mm (0.25 in)

Operating Environment

- Up to 80°C. See the output rating curve chart for your application.
- 0 to 90% RH (relative humidity), non-condensing

Ordering Information

DIN-A-MITE Style A, solid-state power controller

Part Number

D A 1 0 -

-0

Phase

1 = 1-phase, 1 controlled leg

Cooling & Current Rating

0 = Natural convection current rating
18A @ 50°C

Note: See derating curve for current rating at other temperatures.

Line & Load Voltage

02 = 24 to 48V~ (ac)
24 = 120 to 240V~ (ac)
60 = 277 to 600V~ (ac)

Input Type

C0 = 4.5 to 32V= (dc) contactor
K1 = 24 to 48V~ (ac) contactor
K2 = 100 to 120V~ (ac) contactor
K3 = 200 to 240V~ (ac) contactor
F0 = 4 to 20 mA= (dc) proportional

Manual Language

0 = English
1 = German
2 = Spanish
3 = French

Custom Parts Designation

00 = Standard parts

Recommended Fuse and Fuse Holder

Fuse	Watlow Semiconductor	Bussmann Semiconductor	Watlow Combination	Bussmann Combination
20A	17-8020	FWC20A10F	0808-0325-0020	DFJ20
25A	17-8025	FWC25A14F	0808-0325-0025	DFJ25
32A	17-8030	FWP32A14F	0808-0325-0030	DFJ30
40A	17-8040	FWP40A14F	0808-0325-0040	DFJ40

Holders (single)

Fuse	Watlow	Bussmann	Ferraz	Bussmann Combination
20A	17-5110	----	USM1i	----
25A	17-5110	----	USM1i	----
32A	17-5114	----	USM141i	----
40A	17-5114	----	USM141i	----
15 to 30A	0808-0326-1530	----	----	CH30J1i
35 to 60 A	0808-0326-3560	----	----	CH60J1i

Output Rating Curve

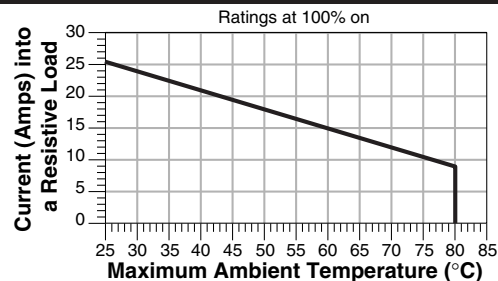

- Installation only tested to 3,000 meters
- Units are suitable for "Pollution degree 2"
- Contactor V= (ac/dc) To increase service life, the cycle time should be less than three seconds

Mounting

- Options include DIN rail or standard back panel mounting.
- The DIN rail specification is: DIN EN 50022, 35 mm by 7.5 mm
- Minimum clipping distance: 34.8 mm (1.37 in)
- Maximum clipping distance: 35.3 mm (1.39 in)
- Mount the cooling fins vertically

Weight

- 323 grams (11.40 oz)

DIN-A-MITE® “A” Power Controller



WATLOW
1241 Bundy Blvd.
Winona, MN 55987 USA

an ISO 9001 approved facility since 1996.

Declares that the following products:

Designation: DIN-A-MITE® “A” Power Control
Model Numbers: DA10 – (02, 24 or 60)(C0, C1, C2, K1, K2, K3, F0 or F1) – 0 (followed by any 3 numbers or letters.)
Classification: Power Control, Installation Category III, Pollution degree 2, IP20
Rated Voltage: 24 to 600 V~ (ac), 50 or 60 Hz

Meets the essential requirements of the following European Union Directives by using the relevant standards show below to indicate compliance.

2004/108/EC Electromagnetic Compatibility Directive

EN 61326-1: 2005 Electrical equipment for measurement, control and laboratory use
– EMC requirements (Industrial Immunity, Class A^{1,2,4} Emissions)
Not for use in a Class B environment without additional filtering.

EN 61000-4-2:2008 Electrostatic Discharge Immunity
EN 61000-4-3:2006 Radiated Field Immunity 10V/m 80 MHz- 1GHz, 3V/m 1.4GHz-2.7GHz
EN 61000-4-4:2011 Electrical Fast-Transient / Burst Immunity
EN 61000-4-5:2006 Surge Immunity
EN 61000-4-6:2008 Conducted Immunity
EN 61000-4-11:2004 Voltage Dips, Short Interruptions and Voltage Variations
EN 61000-3-2:2005 Harmonic Current Emissions
EN 61000-3-3:2005 Voltage Fluctuations and Flicker³

Notes

¹Use of an external filter is required to comply with conducted emissions limits. See note 4 below.

²A Line Impedance Stabilization Network (LISN) was used for conducted emissions measurements.

³To comply with flicker requirements, command signal models F0 and F1 will require a reduced source impedance. Cycle time on ON/OFF models C0, C1, C2 and K1, K2, K3 may need to be up to 175 seconds at 16A.

2006/95/EC Low-Voltage Directive
EN 50178:1997 Electronic equipment for use in power installations.

Per 2002/96/EC W.E.E.E Directive  Please Recycle Properly.

**These devices contain lead solder and are not RoHS compliant.
They are a Control Devices and fall outside the scope of 2002/95/EC Directive.**

⁴Required External EMI Filters for DIN-A-MITE with More Than 6 Amp Loads

An external ElectroMagnetic Interference (EMI) filter must be used in conjunction with the DIN-A-MITE for loads in excess of six amperes (6A) at 150 to 250 KHz.

Watlow has verified that a tank filter will suppress EMI created by SCR power controllers to comply with the conducted emissions limits.

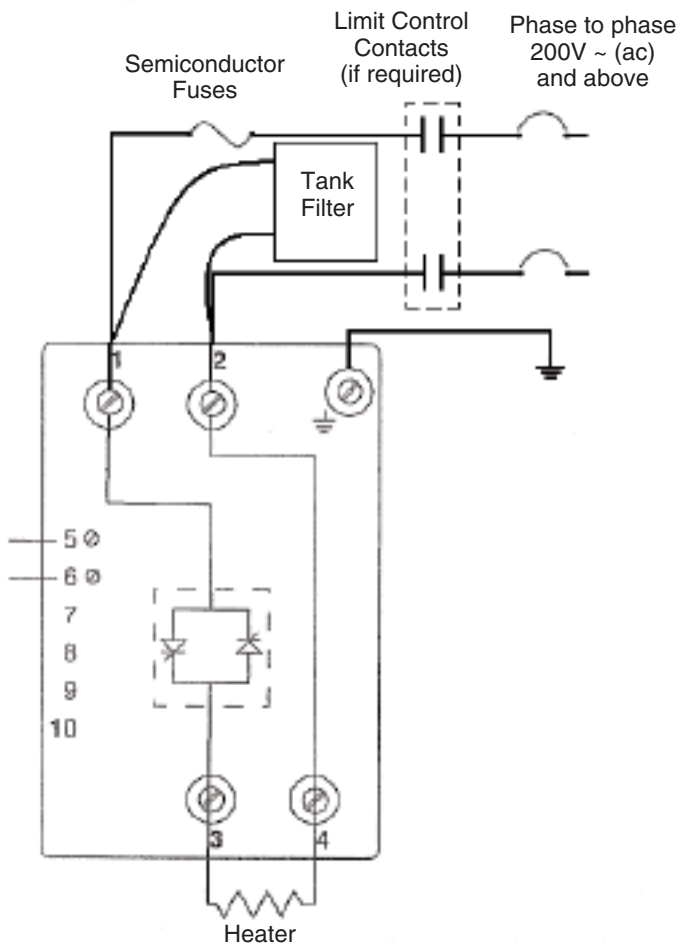

Description	Crydom Filter	Watlow Filter
Single phase 230 v~(ac)	1F25	14-0019



WARNING

Tank filters may suppress desirable communications carried on power lines in the 150 to 250 KHz region. The filters may suppress carrier current such as that used for infant monitors and medical alert systems. Verify that suppressed carrier current or other desirable communications on power lines creates no hazard to people or property. Failure to observe this warning could result in damage to property, and or injury to death for personnel.



WARNING

All filter installation and wiring must be performed by qualified personnel and conform to local and national electrical codes

In-line power filters have been shown to properly suppress EMI; however, these filters must be rated for the entire load current and are generally more expensive than the tank filter specified. An In-line filter may be required if carrier current communications are used on site.

Joe Millanes
Name of Authorized Representative

Winona, Minnesota, USA
Place of Issue

Director of Operations
Title of Authorized Representative

August 2013
Date of Issue

Signature of Authorized Representative

