

Transformer Installation, Operation, and Maintenance Manual

IMPORTANT:
Save this instruction sheet for future use of the product

INTRODUCTION 2

 INSPECTION UPON RECEIVING 2

 STORAGE 2

INSTALLATION & OPERATING SAFETY 2

 TRANSFORMER MOUNTING & SPACING 2

 GROUNDING 2

 WIRE SELECTION 2

 INSPECTION DURING INSTALLATION 2

 INSTALLATION PROCEDURES 3

 INSTALLING OUTDOORS 3

 CABLE TERMINATION 3

 TORQUE VALUES FOR SCREWS AND BOLTS 3

 TRANSFORMER SOUND 5

 GUIDES FOR MINIMIZING TRANSFORMER NOISE 5

TRANSFORMER DESIGN FEATURES 5

 VENTILATED ENCLOSURE STYLE 5

 ENCAPSULATED ENCLOSURE STYLE 5

 INSULATION SYSTEM 5

 SYSTEM LOADING 6

 TRANSFORMER LIFE 6

 CIRCUITS, TAPS AND CONNECTIONS 6

 TRANSFORMER TURNS RATIOS 6

 MAINTENANCE 6

OPTIONAL ACCESSORIES 7

 WEATHER SHIELDS FOR OUTDOOR APPLICATIONS 7

 WALL MOUNTING BRACKETS 7

⚠ WARNING

Electrical potentials hazardous to human life can exist within this equipment when energized. Disconnect all input power before opening case or touching internal parts. Use proper lock-out/tag-out procedures.

The information contained herein may not cover all variations in equipment or provide for all contingencies which might be met in installation, operation and maintenance.

Failure to follow instructions may result in death or serious injury

INTRODUCTION

This manual covers 600 volt class single phase and three phase transformers. Both ventilated (cabinet style) and Encapsulated (potted) styles are covered in this manual.

These instructions set out the limiting factors for satisfactory performance of the transformers. The information contained herein outlines and describes the proper inspection, installation and maintenance of dry type transformers.

Inspection upon Receiving

Transformers should be carefully inspected upon receipt to ensure that no damage has occurred during shipment. Any damage should be reported at once and a claim should be placed against the transportation company.

Storage

Transformers should be stored in a dry location of uniform temperature in their original packing. If storage of an unpacked transformer is to continue for an extended length of time, all ventilating openings should be covered to keep out dust. Outdoor storage is to be avoided, but if necessary, the transformer must be fully protected against moisture and foreign materials. Condensation and absorption of moisture can be reduced by the use of heaters. If the transformer has been subjected to moisture or condensation, it should be dried out before energizing.

INSTALLATION & OPERATING SAFETY

Transformers are provided with access covers to facilitate installation and should never be operated without these access covers securely mounted in place. A safety program must be established, verified and followed by all personnel involved with the transformer.

WARNING

Only qualified personnel should install, inspect, or maintain transformers since the normal operating voltages can be hazardous.

Transformer Mounting & Spacing

Air cooled transformers depend upon the surrounding air for cooling. The free flow of air is important as is the air temperature. A transformer must be mounted so that air can freely circulate all around and through it.

A transformer room must have adequate ventilation and should not be used for storage.

Ventilated Style – Do not place combustible materials on or near transformer or mount transformer closer than 6 inches from any adjacent wall.

Encapsulated Style – Do not place combustible materials on or near transformer or mount transformer closer than 3 inches from any adjacent wall (other than the wall the unit is mounted on). Units should always be mounted vertically.

Transformers must never be mounted next to or above heat generating equipment.

Grounding

Ventilated core and coil assemblies are solidly grounded to the enclosure. On units equipped with electrostatic shields, the shields are grounded to the core.

Encapsulated units have a ground stud located in the wiring compartment. On units equipped with electrostatic shields, the shield wire is connected to the ground stud.

The enclosure should in turn be grounded securely and effectively as a safety precaution.

Grounding must be in accordance with NEC and local electrical codes.

Wire Selection

Connection cables must be rated for at least 90 degrees C insulation and 75 degree C ampacity. Connection cables must meet NEC and local electrical codes.

Inspection during Installation

The transformer should be carefully inspected for any damage due to handling after receipt. The nameplate rating on the unit should be checked against the job specifications to ensure installation of the correct transformer.

The transformer should be connected only as described on its nameplate. Taps should be adjusted, if necessary, to match the available line voltage.

Any bolted electrical connections, including taps, should be checked and tightened since fasteners may have loosened during shipment.

Ventilated – Core and coil hold down nuts (see figure 1) should be loosened to reduce possible sound transmission to the case. The hold-down nuts are designed to be loosened, not removed. Removal will destroy the bolt threads.

Installation Procedures

1. Ensure the area is well ventilated and free from explosive or corrosive gas or vapors.
2. Check the transformer nameplate and verify that it is the correct kVA, frequency, line and load voltage for the application
3. Mount the transformer securely
4. Shut off primary voltage using approved lock-out/tag-out procedures
5. Remove the cover over the wiring compartment.

Note: On ventilated transformers the bottom screws should be loosened and not removed for easier replacement of the cover. See Figure 1

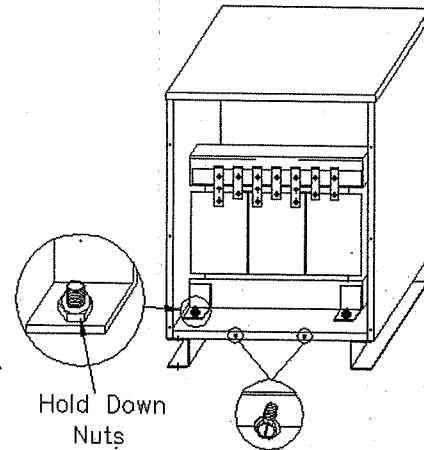

Figure 1 - Front view of Ventilated unit

6. Adjust primary taps if necessary and insulate any unused taps individually. Before changing taps, the protective coating must be removed from the top and bottom of each tap. The tap's surface must be clean and coated with electrical compound before bolting the wire.
7. Route wires into enclosure using the predefined access holes or by creating holes as needed. On ventilated units the wires should enter the unit below the terminals and in front of the coil. See Figure 2
8. Connect the transformer primary according to the wiring diagram on the nameplate.
-SEE CABLE TERMINATION
9. Ground the enclosure in accordance with NEC and local electrical codes.
10. Energize the unit and check the secondary voltage to ensure it is proper for the load.
11. Shut off the primary voltage using approved lock-out/tag-out procedures
12. Connect the load to the secondary terminals according to the wiring diagram on the nameplate
-SEE CABLE TERMINATION

Note: After installation of cables and connectors, a minimum of 1" clearance should be maintained between the enclosure and any energized parts

13. Replace the cover over the wiring compartment
14. Energize the unit.

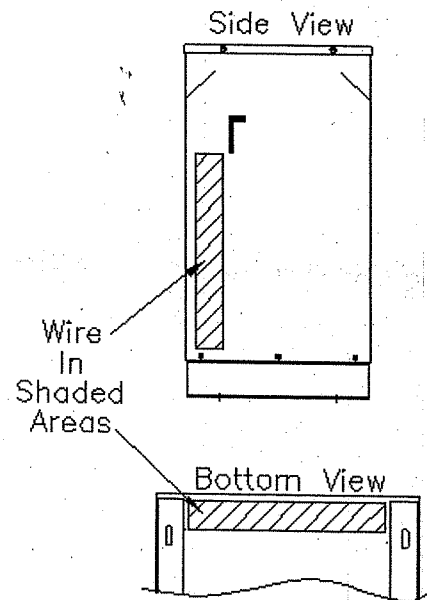

Figure 2 - Side & Bottom View of Ventilated unit

Installing Outdoors

- Select appropriate location to meet applicable codes, cable installation and mounting hardware.
- Use weather shield on ventilated units
- Use water tight couplings on all electrical connections

Cable Termination

To help guard against overheating, the following procedure is recommended when connecting the cables:

- Strip the cable of its insulation to the desired length without ringing or nicking the wire.

Apply a suitable joint compound (such as a PENETROX A, ALNOX-UG, T&B21059, etc.) to the exposed wire and wire brush through it to remove any oxide film from the other strands.

Insert the wire into the lug. Make certain all the strands are contained and then tighten the wire retaining screw securely per **Table A**. This operation should result in compound oozing out from between the individual strands of the wire. If this does not happen, it is an indication that an insufficient quantity of compound was used.

Wipe the excess compound from the area adjacent to the wire connection. Note: Some compounds contain metallic particles, which could reduce the dielectric strength of the insulating material employed.

After a few seconds, re-tightening the wire retaining screw per **Table A**.

Coat both surfaces with a copper-aluminum joint compound.

Bend the cable so the hole in the lug aligns with the hole in the terminal and contact surfaces are in good contact alignment.

Insert the bolt with a flat washer under the head through the holes of the lug and the terminal. Add a flat washer, lock washer and a nut on the opposite side (see **Figure 3**). Tighten per **Table B**.

CAUTION:

There must not be any washers between the terminals and the lugs (see **Figure 3**).

Align the cables so adequate electrical clearances are maintained per NEC-373-11.

If electrical clearances are questionable, the exposed electrical connection should be insulated with electrical tape.

TABLE A	
WIRE SIZE	TORQUE IN-LB
14-8	75
6-4	100
3-1	125
1/0-2/0	150
3/0-200	200
250-400	250
500-750	300

TABLE B	
BOLT SIZE	TORQUE IN-LB
1/4"	80
5/16"	180
3/8"	240

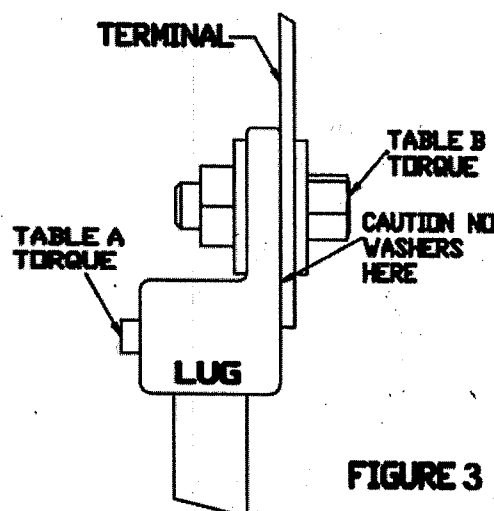

FIGURE 3

Torque Values for Screws and Bolts

When re-attaching the cover to the wiring compartment be within 5 % of 66 in-lbs. Tightening the screws more than this may strip the threads.

When attaching the wires to the terminals use the recommended bolts for the wiring lugs. It is recommended to use two wrenches when tightening or loosening bolted connections to prevent damage. The chart below shows recommended torque values for standard size bolts.

Torque Values for Screws and Bolts	
Screw/bolt Size (SAE Grade 2)	Torque Value (+/- 5 %)
6-32	10 in-lbs
6-40	12 in-lbs
8-32	19 in-lbs
8-36	20 in-lbs
10-24	27 in-lbs
10-32	31 in-lbs
1/4 -20	66 in-lbs
1/4 -28	76 in-lbs
5/16-18	11 ft-lbs
5/16-24	12 ft-lbs
3/8-16	20 ft-lbs
3/8-24	23 ft-lbs
7/16-14	30 ft-lbs
7/16-20	35 ft-lbs
1/2 -13	50 ft-lbs
1/2 -20	55 ft-lbs
9/16-12	70 ft-lbs
9/16-18	80 ft-lbs
5/8-11	100 ft-lbs
5/8-18	110 ft-lbs

Transformer Sound

Transformers, like other electromagnetic devices, produce sound whose primary cause is the magnetic energy in the transformer core. The relative loudness of the sound depends upon the construction of the transformer, the manner of installation, the ambient sound level of the installation and the sensitivity of the individual listener.

Transformers are designed to have an average sound level below industry sound level limits when tested in accordance with NEMA ST 20 (IEEE C57.12.91 sec 13).

The NEMA maximum allowable averages of the readings in decibels are as follows:

Transformer kVA Rating	NEMA Maximum dB* Ratings
0-9	40
10-50	45
51-150	50
151-300	55
301-500	60
501-700	62
701-1000	64

*Decibels-Unit for measuring the loudness of sound.

Guides for Minimizing Transformer Noise

Proper installation of the transformer is required since a quiet transformer can develop objectionable sound levels unless certain basic rules are followed.

For a Quiet Installation:

- Consider the installation and location of the transformer before the building is built. Building modifications to correct sound can be expensive.
- Place sound dampening pads between the transformer and its mounting surface.
- Use flexible conduit coupling between the transformer and the wiring system.
- Install transformer as far away as possible from any area where sound is objectionable.

TRANSFORMER DESIGN FEATURES

Ventilated enclosure Style

Ventilated style power transformers are 600 Volt Class units with ventilated enclosures for natural draft cooling.

They are designed for indoor and, with the appropriate weather shields, outdoor installations.

On smaller kVA sizes a wiring compartment, located below the core and coil, provides cool operation and accessibility of connections. Primary and secondary terminals share the same board. Larger units are top terminated, front and/or rear, permitting the use of raceway bus or conduit connections. All units are shipped connected for nominal line voltage.

These units can be floor or platform mounted but must always be in a vertical position with the mounting feet down.

The ventilating openings of this transformer must not be blocked or restricted in any way that will reduce the flow of air through the transformer.

Encapsulated enclosure Style

Encapsulated style power transformers are 600 Volt Class units with the transformer sealed with a mix of sand and resin. They are designed for indoor or outdoor installations.

The wiring compartment, typically located below the core and coil, provides cool operation and accessibility of connections.

Encapsulated units should be wall mounted with the wiring compartment at the bottom. Some larger units are floor mounted with the wiring compartment on the top.

Insulation System

Ventilated transformers are designed and manufactured with UL Recognized Class 220°C insulation systems. These systems are rated for operation in an environment with a maximum ambient temperature of 40°C.

Average winding temperature rises are rated at 80°C, 115°C and 150°C above ambient temperature. See transformer nameplate for product specific information.

The insulation rating is guaranteed for altitudes of less than 3300 feet (1005 m) above sea level.

Encapsulated transformers are designed and manufactured with UL Recognized Class 105°C, 130°C, or 180°C insulation systems. These systems are rated for operation in an environment with a maximum ambient temperature of 25°C.

Average winding temperature rises are rated at 70°C, 95°C and 115°C above ambient temperature. See transformer nameplate for product specific information.

The insulation rating is guaranteed for altitudes of less than 3300 feet (1005 m) above sea level. Typically configured transformers will feel hot to touch.

System Loading

Overloading, operating in ambient temperatures greater than 40 C and/or elevation greater than 3300 feet will result in reduction of transformer life unless de-rating of the unit is calculated using IEEE Loading Guide in IEEE C57.96.

Fully loaded transformers may appear excessively warm to the touch, particularly on the top cover of the unit. Standards permit the cover temperature to reach 65 C over ambient temperature. This represents normal heating and should not cause concern.

Overloads can be tolerated without exceeding the maximum allowable insulation temperature provided the overload is of short time duration and is preceded and followed by a period of operation at less than rated kVA. The actual conditions and characteristics of the loading cycle must be known in order to calculate the proper kVA rating of the transformer. Refer to Guide for Loading of Dry Type Transformers IEEE C.57.96.

Ambient temperatures above 30° C average with a 40° C maximum require either larger kVA ratings or special low temperature rise transformers.

Altitude correction for application of a standard transformer in altitudes above 3300 feet can be made by reducing the load. Refer to Altitude Correction Factor in IEEE C57.96.

Transformer Life

Transformer life is dependent upon the thermal degradation of the insulation system which in turn is dependent upon the winding temperature and duration of operation at that temperature.

This is a high quality product, however, it is possible to misapply or unknowingly abuse a transformer and thus reduce its life.

Factors which affect transformer life are line voltage, load current, load cycle, ambient temperature, and other environmental conditions such as moisture, corrosive atmosphere, vibration, and maintenance. Normal conditions of operation are covered in this standard operating procedure and various Industry Standards.

Circuits, Taps and Connections

Circuits- Three phase transformers may have Delta or Wye inputs with Delta or Wye connected outputs. The most common is Delta input with a Wye output. A Delta input to Delta output is also common. The Delta output may have a center tap for lighting purposes. This center tap is designed for a maximum of 5% of the nameplate kVA.

Single-phase transformers may have up to four input and four output terminals. Four input terminals accommodate a single input voltage when inter-

connected. Four output terminals provide a single output voltage or two voltages and a neutral when inter-connected.

Proper connections for transformers are those described on the nameplate of the transformer.

Taps – Transformers are normally supplied with full-capacity primary taps. A typical tap arrangement is two 2 ½ percent taps above nominal voltage (FCAN) and four 2 ½ percent taps below (FCBN). Transformers are shipped with the taps connected for nominal voltage. A qualified electrician must change the taps if the supply voltage on the job site differs from the nominal voltage rating of the transformer. Jumpers for tap connections are provided with transformers.

Connections- Input and output wires must be connected to their respective terminals with an appropriately sized lug rated for the input or output current. The input and output lugs, which are not provided with the transformers, must be suitable for aluminum or copper transformer terminals.

Transformer terminals are identified with H's for high voltage and X's for low voltage in accordance with NEMA ST-20.

Minimum wire sizes for the source and load side of the transformer must be as specified in the current version of the NEC in table 310-16 in the 75° C column.

Transformer Turns Ratios

All transformers 3 kVA and larger are wound with exact turns ratios according to their voltage rating. This means that they can be used for either step up or step down applications. If a Delta-Wye transformer is wired in reverse (Wye to Delta) application, then its neutral should not be connected.

Maintenance

Transformers contain no moving parts and require very little maintenance. Periodic inspection and care are recommended practices especially if the transformer is operating in a harsh environment.

WARNING

Transformer must be de-energized prior to any maintenance. Failure to de-energize before opening the enclosure may result in serious personal injury.

Inspect for loose connections, condition of terminal board, condition of splices, overheating, rust, paint deterioration and general condition of the unit. Corrective measures should be taken if necessary.

Removal of dust, dirt and debris from the external enclosure surfaces is encouraged and may be performed while the transformer is in operation.

If maintenance includes removal of enclosure panels, the transformer must be de-energized. The use of lock-out/tag-out practices is required.

Internal maintenance would include:

- Inspection and tightening of bolted connections.
- Inspection of coil ducts. Removal of dirt can be accomplished using a vacuum cleaner or low-pressure (<20 psi) dry compressed air.

OPTIONAL ACCESSORIES

Weather shields for Outdoor Applications

The environmental rating of the ventilated transformer enclosure may be elevated from NEMA 1 to NEMA 3R by the addition of weather shields. Weather shields are supplied in kits specific to the enclosure. They must be installed following directions included in the kit. In cases where a weather shield may be installed, the part number of the weather shield kit appears on the transformer nameplate. Verify that the kit number and nameplate number match.

Note: 6" from wall requirement does NOT include the weather shield. All transformers should be marked to show a separation of clearance no less than 6 in. (152 mm) from any side of the enclosure to the adjacent wall.

Weather Shield Kit Dimensional Data

kVA Rating*	Width (Inches)	Standard Depth (Inches)	Depth with Weather Shield (Inches)
Single Phase Units			
15	15"	14"	21"
25	15"	15"	22"
37.5	17"	17"	24"
50	20"	18"	25"
75	22"	20"	27"
100	22"	22"	30"
Three Phase Units			
15	17"	14"	21"
30	19"	16"	23"
45	22"	17"	24"
75	25"	18.5"	25.5"
112.5	27"	21"	28"
150	29"	23"	31"
225	33"	26"	34"
300	35"	30"	38"
500	48"	33"	43.5"

* kVA rating for 150° C Temp Rise Ventilated units

Wall Mounting Brackets

Floor mount transformers (up to about 75 kVA depending on style and weight) may be mounted on a wall using specially designed wall mounting brackets supplied in kits and specific to the enclosure. They must be installed following directions included in the kit.

It is important to check the weight of the unit and confirm that the wall and the fasteners (not supplied with the kit) can support the unit.

