

EZ-ZONE® PM Controllers Take the Pain Out of Meeting Your Thermal Loop Requirements

The EZ-ZONE® PM panel mount controller from Watlow® offers control options to reduce system complexity and the cost of thermal loop ownership. It can be ordered as a PID controller, an over/under limit controller or its functions can be combined into an integrated controller. An option to integrate a high amperage power controller output with a high-performance PID controller and an over/under limit controller in one space-saving, panel mount package is also available. Many communication options are offered to support connectivity needs.

Because the EZ-ZONE PM controller is highly scalable, pay only for what is needed. This controller is available in 1/2, 1/6, 1/8 and 1/4 DIN panel mount packages. The EZ-ZONE PM controller is easy to use and is ideal for PID, over/under limit or integrated controller needs.

Features and Benefits

Integrated PID and limit controller

- Reduces wiring time and termination complexity compared with connecting discrete products
- Decreases required panel space
- Lowers installation costs
- Increases user and equipment safety for over/under temperature conditions

High amperage power control output

- Drives 15 ampere resistive loads directly
- Reduces component count
- Decreases cost of ownership

Current monitoring

- Detects heater current flow and provides alarm indication of a failed output device or heater load

Serial communication capabilities

- Provides a wide range of protocol choices including Modbus® RTU, EtherNet/IP™, Modbus® TCP, PROFIBUS DP and DeviceNet™
- Supports network connectivity to a PC or PLC

Dual-channel controller

- Provides two PID controllers in one space-saving package

Enhanced control options

- Easily handles complex process problems such as cascade, ratio, differential, square-root, motorized valve control without slidewire feedback, wet-bulb/dry-bulb, compressor control and peltier loads

Advanced PID control algorithm

- Offers TRU-TUNE®+ adaptive control to provide tighter control for demanding applications
- Provides auto-tune for fast, efficient start-up



Configuration communications with software

- Includes Watlow standard bus communications and EZ-ZONE configurator software
- Saves time and improves reliability of controller setup

Ten-point linearization curve

- Improves sensor accuracy

Built-in sensor compensation curves

- Saves cost of buying compensated sensors
- Includes Vaisala RH and altitude (pressure) curves

Remote set point operation

- Supports convenient set point manipulation from a remote device such as a master control or PLC

Profile capability

- Offers pre-programmed process control
- Allows ramp/soak programming with 40 total steps, battery backup and real time clock

Retransmit Output

- Supports industry needs for recording

Factory Mutual (FM) approved over/under limit with auxiliary outputs

- Increases user and equipment safety for over/under temperature conditions

Memory for saving and restoring parameter settings

- Decreases service calls and time down

Agency approvals: UL® listed, CSA, CE, RoHS, W.E.E.E., FM, SEMI F47-0200, Class 1, Div. 2 rating on selected models

- Assures prompt product acceptance
- Reduces end product documentation costs

Touch-safe package

- Increases safety for installer/operator
- Complies with IP2X requirements

Consistent termination labeling connection system

- Simplifies switching between products
- Speeds up user's system documentation

EZ-KEY

- Enables simple, one-touch operation of user-defined, repetitive activities

Programmable menu system

- Reduces setup time and increases operator efficiency

Three-year warranty

- Provides product support and reliability

ISO 9001



Registered Company
Winona, Minnesota USA

WIN-EZPM-0112

 **WATLOW®**
Better Thermal Solutions...Faster

Specifications

Controller

- User-selectable heat/cool, on-off, P, PI, PD, PID or alarm action, not valid for limit controllers
- Auto-tune with TRU-TUNE+ adaptive control algorithm
- Control sampling rates: input = 10Hz, outputs = 10Hz

Profile Ramp/Soak - Real Time Clock and Battery Backup

- 4 profiles, 40 total steps
- Accuracy (typical): ± 30 PPM at 77°F (25°C)
+30/-100 PPM at -4 to 149°F (-20 to 65°C)
- Battery type/typical life: lithium, three cumulative years unpowered at 77°F (25°C)

Isolated Serial Communications

- EIA 232/485, Modbus® RTU
- EtherNet/IP™/Modbus® TCP
- DeviceNet™
- PROFIBUS DP

Wiring Termination—Touch-Safe Terminals

- Input, power and controller output terminals are touch safe, removable, 12 to 22 AWG

Universal Input

- Thermocouple, grounded or ungrounded sensors greater than 20M Ω input impedance, 3 μ A open sensor detection, 2k Ω source resistance max.
- RTD 2- or 3-wire, platinum, 100 Ω and 1000 Ω @ 32°F (0°C) calibration to DIN curve (0.00385 $\Omega/\Omega/^\circ\text{C}$)
- Process, 0-20mA @ 100 Ω , or 0-10VDC @ 20k Ω , 0-50mV at 20M Ω , 0-1000 Ω potentiometer; scalable; inverse scaling

Functional Operating Range

Type J: -346 to 2192°F (-210 to 1200°C)
Type K: -454 to 2500°F (-270 to 1371°C)
Type T: -454 to 750°F (-270 to 400°C)
Type E: -454 to 1832°F (-270 to 1000°C)
Type N: -454 to 2372°F (-270 to 1300°C)
Type C: 32 to 4200°F (0 to 2315°C)
Type D: 32 to 4200°F (0 to 2315°C)
Type F: 32 to 2449°F (0 to 1343°C)
Type R: -58 to 3214°F (-50 to 1767°C)
Type S: -58 to 3214°F (-50 to 1767°C)
Type B: 32 to 3300°F (0 to 1816°C)
RTD (DIN): -328 to 1472°F (-200 to 800°C)
Process: -1999 to 9999 units

Accuracy

- Calibration accuracy and sensor conformity: $\pm 0.1\%$ of span, $\pm 1^\circ\text{C}$ @ the calibrated ambient temperature and rated line voltage
 - Types R, S, B; 0.2%
 - Type T below -50°C; 0.2%
- Calibration ambient temperature @ 77°F $\pm 5^\circ\text{F}$ (25°C $\pm 3^\circ\text{C}$)
- Accuracy span: 1000°F (540°C) min.
- Temperature stability: $\pm 0.1^\circ\text{F}/^\circ\text{F}$ ($\pm 0.1^\circ\text{C}/^\circ\text{C}$) rise in ambient max.

Thermistor Input

- 0 to 40k Ω , 0 to 20k Ω , 0 to 10k Ω , 0 to 5k Ω
- 2.252k Ω and 10k Ω base at 77°F (25°C)
- Linearization curves built-in

Current Transformer Input

- Accepts 0-50mA signal (user-programmable range)
- Displayed operating range and resolution can be scaled and are user-programmable

Digital Inputs (DC Voltage)

- Max. input: 36V at 3mA
- Logic: min. high state 3V at 0.25mA, max. low state 2V

Digital Inputs (Dry Contact)

- Logic: min. open resistance 10k Ω , max. closed resistance 50 Ω
- Max. short circuit: 20mA

2 Digital I/O (ordered with power supply option)

- Update rate: 10Hz
- Input type: user-selectable, dc voltage or dry contact
- Output type: switched dc
- Output voltage: 24V
- Output 5: 24mA max. or drive one 3-pole DIN-A-MITE®
- Output 6: 10mA max.

6 Digital I/O (ordered with communications option)

- Update rate: 10Hz
- Input type: user-selectable, dc voltage or dry contact
- Output type: user-selectable, switched dc or open collector
- Switched dc output voltage: 12 to 24VDC, depending on current draw
- Switched dc max. supplied current: 40mA at 20VDC and 80mA at 12VDC
- Switched dc max. low state: 2V
- Open collector max. switched voltage: 32VDC
- Open collector max. switched current: 1.5A per output; 8A total for all 6 outputs

Output Hardware

- Switched dc: 22 to 32VDC @ 30mA max. per single output and 40mA max. total per paired outputs (1 & 2, 3 & 4)
- Open collector: 30VDC max. @ 100mA max.
- SSR, Form A, 24 to 240VAC, 1A at 50°F (10°C) to 0.5A at 149°F (65°C) resistive load, 264VAC max., opto-isolated, without contact suppression, 120/240VAC @ 20VA pilot duty
- Electromechanical relay, Form A, 24 to 240VAC or 30VDC max., 5A resistive load, 100,000 cycles at rated load, 120/240 @ 125VA or 24VAC @ 25VA pilot duty
- Electromechanical relay, Form C, 24 to 240VAC or 30VDC max., 5A resistive load, 100,000 cycles at rated load, 120/240 @ 125VA or 24VAC @ 25VA pilot duty
- NO-ARC relay, Form A, 85 to 264VAC, 15A @ 122°F (50°C), resistive load, no VDC, 2,000,000 cycles at rated load
- Universal process output: range selectable; 0 to 10VDC $\pm 15\text{mV}$ into a min. 1,000 Ω load with 2.5mV nominal resolution; 0 to 20mA $\pm 30\mu\text{A}$ into max. 800 Ω load with 5 μA nominal resolution; temperature stability 100ppm/°C

Operator Interface

- Dual 4-digit, 7-segment LED displays
- Advance, infinity, up and down keys, plus 1 or 2 programmable EZ-KEY(s) depending on model size
- Typical display update rate: 1Hz
- RESET key substituted for infinity on all models with limit controller

Line Voltage/Power

- High voltage option: 85 to 264VAC, 47 to 63Hz
- Low voltage option: 20 to 28VAC, +10/-15%; 50/60Hz, $\pm 5\%$ or 12 to 40VDC
- Max. power consumption: 10VA ($\frac{1}{32}$ and $\frac{1}{16}$ DIN); 14VA ($\frac{1}{8}$ and $\frac{1}{4}$ DIN)
- Data retention upon power failure via nonvolatile memory
- Compliant with SEMI F47-0200, Figure R1-1 voltage sag requirements @ 24VAC or higher

Environment

- Operating temperature: 0 to 149°F (-18 to 65°C)
- Storage temperature: -40 to 185°F (-40 to 85°C)
- Relative humidity: 0 to 90% RH, non-condensing

Agency Approvals

- cULus® UL/EN/CSA C22.2 No 61010-1 Listed, File E185611
- CSA C22.2 No. 24, File 158031 ($\frac{1}{32}$ and $\frac{1}{16}$ DIN sizes)
- UL® 50 4X indoor locations, NEMA 4X, IP66 front seal
- cULus® ANSI/ISA 12.1201-2001, CSA-C22.2 No. 213-1987, Class 1, Div. 2, Groups A, B, C and D, Temperature Code T4A, File E184390 (optional)
- FM Class 3545 (limit controls)
- CE, RoHS by design, W.E.E.E.
- EtherNet/IP™ and DeviceNet™ ODVA Conformance Tested

Comparison of Available Features

	1/32 DIN	1/16 DIN	1/8 DIN	1/4 DIN
PID Loops	1	1	1 to 2	1 to 2
Profile Ramp/Soak	40 total steps	40 total steps	40 total steps	40 total steps
Profile Battery Backup and Real Time Clock	None	None	Yes	Yes
Number of Digital Inputs/Outputs	0 to 2	0 to 2	0 to 8	0 to 8
Number of Outputs	1 to 4	1 to 6	1 to 12	1 to 12
Integrated Safety Limits	Limit must be ordered as separate device	1	1	1
Maximum Power Output	5A mechanical relay	15A NO-ARC	15A NO-ARC	15A NO-ARC
Current Measurement	None	Accepts 0-50mA signal from external current transformer		
Standard Bus Communications	Yes	Yes	Yes	Yes
Field Bus Communications	Modbus® RTU 485	Modbus® RTU 232/485, EtherNet/IP™, Modbus® TCP, DeviceNet™, PROFIBUS DP		
10-Point Calibration Offset	Yes	Yes	Yes	Yes
Ratio, Differential and Square-Root	None	Yes	Yes	Yes
Sensor Compensation Curves - Altitude (Pressure) and Vaisala RH	None	Yes	Yes	Yes
Motorized Valve Control (without Feedback)	None	Yes	Yes	Yes
Wet Bulb/Dry Bulb	None	Yes	Yes	Yes
Cascade	None	None	Yes	Yes

Compatible Accessories

More information is available on these products at www.watlow.com

EZ-ZONE® configurator software is used to set up Watlow EZ-ZONE products in one simple process. It works without requiring the purchase of any communications options because it uses the standard bus communications protocol that is included with all EZ-ZONE products. EZ-ZONE configurator can be used for on-line and off-line configuration and downloading previously saved setups. It is available free as a download at www.watlow.com

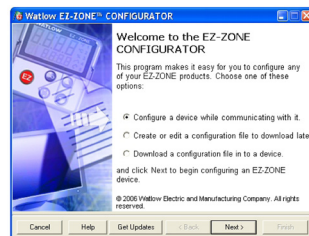

Silver Series touchscreen operator interface terminals provide a customizable user interface and log and graph data for Watlow controllers and other devices. A Silver Series operator interface terminal paired with Watlow controllers is the perfect solution for your industrial process or machine control application.

SpecView from Watlow is designed for industrial users with features such as data logging, trending and support for bar code readers and touch screens. Errors are reduced, for any process, by creating application-specific screens. The software provides a historical replay option, easy-to-use recipe features and remote access options, including LAN, internet and modem.



Dimensional Drawings

EZ-ZONE PM 1/32 DIN

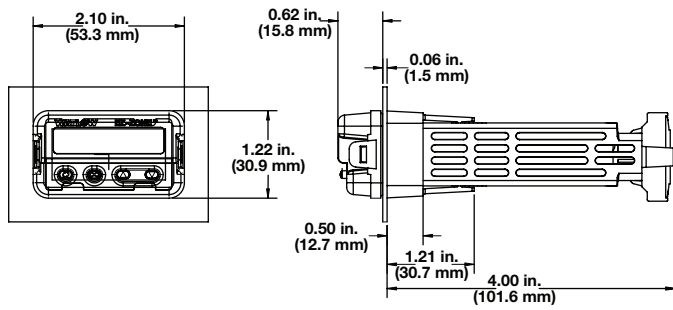

EZ-ZONE PM 1/6 DIN

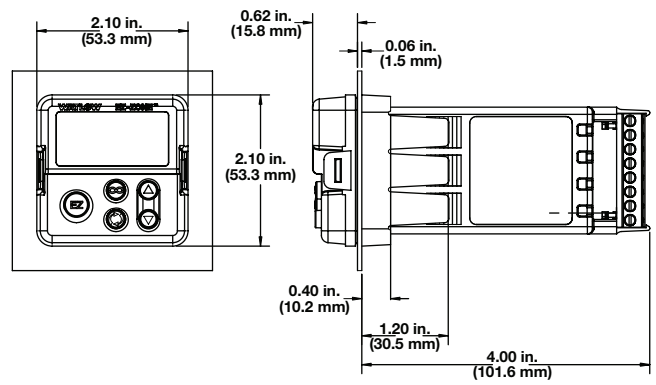

EZ-ZONE PM 1/8 DIN - Horizontal

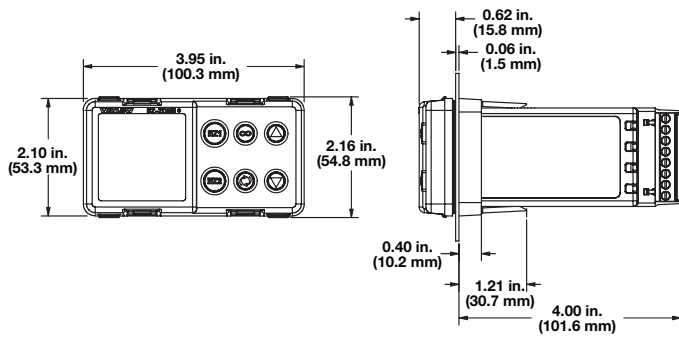

EZ-ZONE PM 1/8 DIN - Vertical

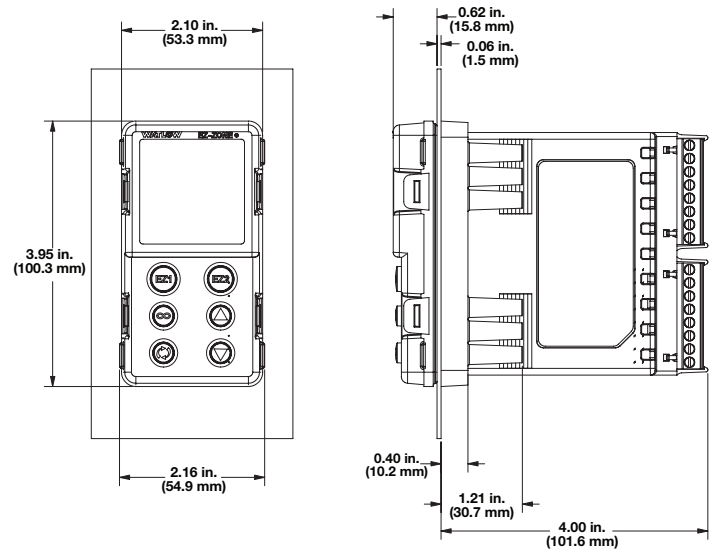

EZ-ZONE PM 1/4 DIN

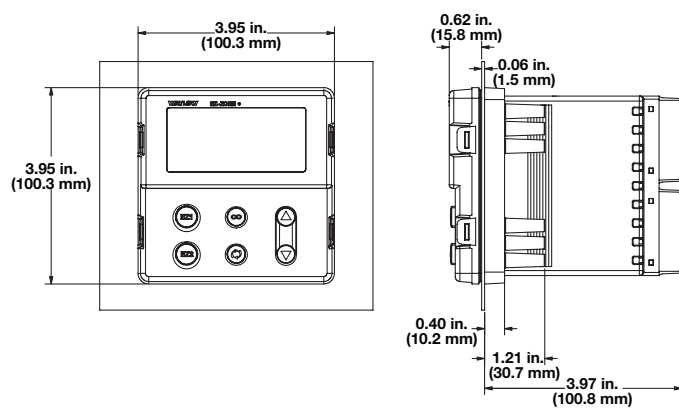

PID Model Ordering Information

Universal Sensor Input, Standard Bus Communications, TRU-TUNE+ Adaptive Tune, Red and Green Seven-Segment Displays

Part Number

1 2	3	4	5	6 7	8	9 10 11	12	13 14
	Package Size	Primary Function	Power Supply, Digital I/O	Output 1 and 2 Hardware Options	Add'l Comm. Options	Future Options	Isolated Input Option	Custom Options
PM					-	AAA		

3 Package Size	
3 =	1/2 DIN
6 =	1/6 DIN
8 =	1/8 DIN vertical
9 =	1/8 DIN horizontal
4 =	1/4 DIN

4 Primary Function	
Options B and E are not available with 1/2 DIN (PM3) or 1/6 DIN (PM6) models	
C =	PID controller with universal input
R =	PID controller with universal input and profiling ramp/soak
B =	PID controller with universal input and profiling ramp/soak and battery back-up with real time clock
J =	PID controller with thermistor
N =	PID controller with thermistor input and profiling ramp/soak
E =	PID controller with thermistor input and profiling ramp/soak and battery back-up with real time clock
S =	Custom firmware

5 Power Supply, Digital Inputs/Outputs (I/O)	
1 =	100 to 240VAC
2 =	100 to 240VAC plus 2 digital I/O points
3 =	20 to 28VAC or 12 to 40VDC
4 =	20 to 28VAC or 12 to 40VDC, plus 2 digital I/O points

6 7 Output 1 and 2 Hardware Options		
PM3: CH, EH and KH are not valid options for 1/2 DIN package type		
	Output 1	Output 2
CA =	Switched dc/open collector	None
CH =	Switched dc/open collector	NO-ARC 15A power control
CC =	Switched dc/open collector	Switched dc
CJ =	Switched dc/open collector	Mechanical relay 5A, Form A
CK =	Switched dc/open collector	SSR Form A, 0.5A
EA =	Mechanical relay 5A, Form C	None
EH =	Mechanical relay 5A, Form C	NO-ARC 15A power control
EC =	Mechanical relay 5A, Form C	Switched dc
EJ =	Mechanical relay 5A, Form C	Mechanical relay 5A, Form A
EK =	Mechanical relay 5A, Form C	SSR Form A, 0.5A
FA =	Universal process	None
FC =	Universal process	Switched dc
FJ =	Universal process	Mechanical relay 5A, Form A
FK =	Universal process	SSR Form A, 0.5A
AK =	None	SSR Form A, 0.5A
KH =	SSR Form A, 0.5A	NO-ARC 15A power control
KK =	SSR Form A, 0.5A	SSR Form A, 0.5A

8 Additional Communication Options	
Standard bus always included	
A =	None
1 =	EIA 485 Modbus® RTU

12 Isolated Input Option	
A =	None
D =	Isolated input 1

13 14 Custom Options	
Firmware, overlays, parameter settings	
AA =	Standard EZ-ZONE PM face plate
12 =	Class 1, Div. 2 (not available with mechanical relay Output types E, H or J)

Limit Model Ordering Information

Universal Sensor Input, Standard Bus Communications, Red and Green Seven-Segment Displays

Part Number

① ②	③	④	⑤	⑥ ⑦	⑧	⑨ ⑩ ⑪	⑫	⑬ ⑭
PM	Package Size	Primary Function	Power Supply, Digital I/O	Output 1 and 2 Hardware Options	Add'l Comm. Options	Future Options	Isolated Input Option	Custom Options
					-	AAA		

③ Package Size	
3 =	1/2 DIN
6 =	1/6 DIN
8 =	1/2 DIN vertical
9 =	1/2 DIN horizontal
4 =	1/4 DIN

④ Primary Function	
L =	Limit controller with universal input
M =	Limit controller with thermistor input
D =	Custom firmware

⑤ Power Supply, Digital Inputs/Outputs (I/O)	
1 =	100 to 240VAC
2 =	100 to 240VAC plus 2 digital I/O points
3 =	20 to 28VAC or 12 to 40VDC
4 =	20 to 28VAC or 12 to 40VDC, plus 2 digital I/O points

⑥ ⑦ Output 1 and 2 Hardware Options		
	Output 1	Output 2
AJ =	None	Mechanical relay 5A, Form A
CJ =	Switched dc/open collector	Mechanical relay 5A, Form A
EJ =	Mechanical relay 5A, Form C	Mechanical relay 5A, Form A

⑧ Additional Communication Options	
Standard bus always included	
A =	None
1 =	EIA 485 Modbus® RTU

⑫ Isolated Input Option	
A =	None
D =	Isolated input 1

⑬ ⑭ Custom Options	
Firmware, overlays, parameter settings	
AA =	Standard EZ-ZONE PM face plate

Typical Block Diagrams

EZ-ZONE PM PID Model

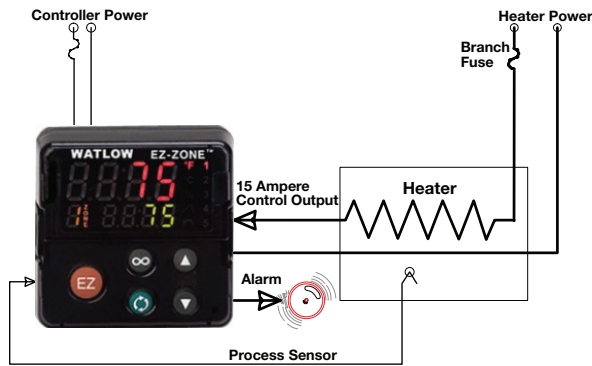

EZ-ZONE PM Limit Model

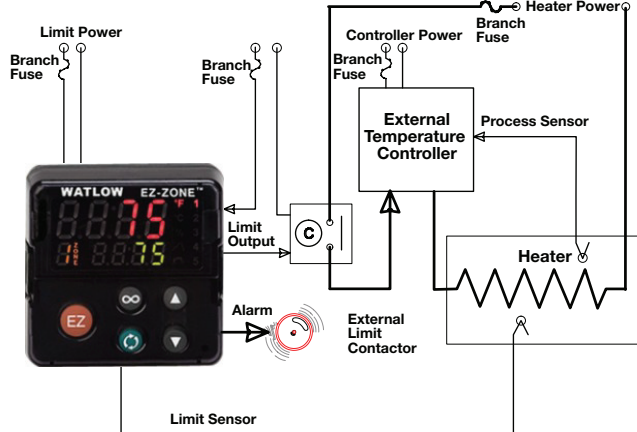

EZ-ZONE PM Integrated PID Model

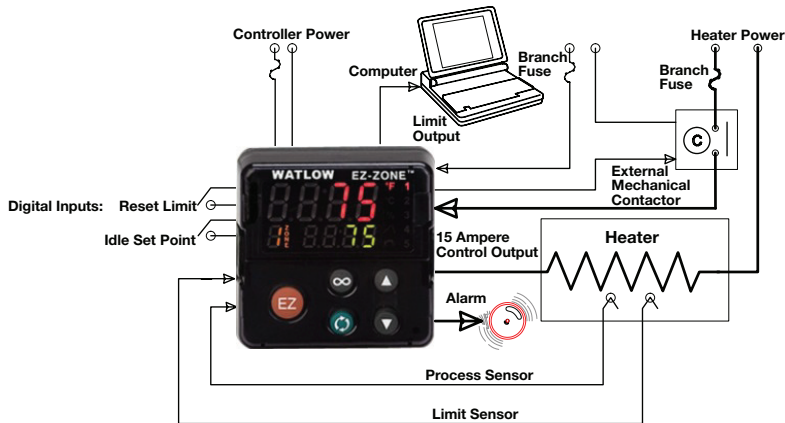

Integrated PID Controller Model Ordering Information

Universal Sensor Input, Standard Bus Communications, TRU-TUNE+ Adaptive Tune, Red and Green Seven-Segment Displays

Part Number

① ②	③	④	⑤	⑥ ⑦	⑧	⑨	⑩ ⑪	⑫	⑬ ⑭
PM	Package Size	Primary Function	Power Supply, Digital I/O	Output 1 and 2 Hardware Options	Comm. Options or Add'l Digital I/O	Auxiliary Control Functions	Output 3 and 4 Hardware Options	Additional Options	Custom Options

③ Package Size	
6 =	1/6 DIN
8 =	1/6 DIN vertical
9 =	1/6 DIN horizontal
4 =	1/4 DIN

④ Primary Function	
Options B and E are not available with 1/6 DIN (PM6) models	
C =	PID controller with universal input
R =	PID controller with universal input and profiling ramp/soak
B =	PID controller with universal input and profiling ramp/soak and battery back-up with real time clock
J =	PID controller with thermistor input
N =	PID controller with thermistor input and profiling ramp/soak
E =	PID controller with thermistor input and profiling ramp/soak and battery back-up with real time clock
S =	Custom firmware

⑤ Power Supply, Digital Inputs/Outputs (I/O)	
1 =	100 to 240VAC
2 =	100 to 240VAC plus 2 digital I/O points
3 =	20 to 28VAC or 12 to 40VDC
4 =	20 to 28VAC or 12 to 40VDC, plus 2 digital I/O points

⑥ ⑦ Output 1 and 2 Hardware Options		
	Output 1	Output 2
CA =	Switched dc/open collector	None
CH =	Switched dc/open collector	NO-ARC 15A power control
CC =	Switched dc/open collector	Switched dc
CJ =	Switched dc/open collector	Mechanical relay 5A, Form A
CK =	Switched dc/open collector	SSR Form A, 0.5A
EA =	Mechanical relay 5A, Form C	None
EH =	Mechanical relay 5A, Form C	NO-ARC 15A power control
EC =	Mechanical relay 5A, Form C	Switched dc
EJ =	Mechanical relay 5A, Form C	Mechanical relay 5A, Form A
EK =	Mechanical relay 5A, Form C	SSR Form A, 0.5A
FA =	Universal process	None
FC =	Universal process	Switched dc
FJ =	Universal process	Mechanical relay 5A, Form A
FK =	Universal process	SSR Form A, 0.5A
AK =	None	SSR Form A, 0.5A
KH =	SSR Form A, 0.5A	NO-ARC 15A power control
KK =	SSR Form A, 0.5A	SSR Form A, 0.5A

⑧ Communication Options or Additional Digital Inputs/Outputs (I/O)	
Standard bus always included	
A =	None
1 =	EIA 485 Modbus® RTU
2 =	EIA 232/485 Modbus® RTU
3 =	EtherNet/IP™/Modbus® TCP
5 =	DeviceNet™
6 =	PROFIBUS DP
C =	6 digital I/O (not available on 1/6 DIN models)
D =	6 digital I/O and EIA 485 Modbus® RTU (not available on 1/6 DIN models)

⑨ Auxiliary Control Functions	
A =	None
C =	2nd PID channel with universal input - not available on 1/6 DIN models
J =	2nd PID channel with thermistor input - not available on 1/6 DIN models
R =	Auxiliary 2nd input (universal input)
P =	Auxiliary 2nd input (thermistor input)
T =	Current transformer input (not valid Output 3 and 4 selections = FA, FC, FJ and FK)
L =	Integrated limit controller with universal input (only valid Output 3 and 4 selections = CJ, EJ and AJ)
M =	Integrated limit controller with thermistor input (only valid Output 3 and 4 selections = CJ, EJ and AJ)
1/6 DIN Models: If communication options 2 thru 6 is ordered in previous digit, then Option A must be ordered here.	
All Models: Auxiliary input supports remote set point, backup sensor ratio, differential and wet-bulb/dry-bulb input.	

⑩ ⑪ Output 3 and 4 Hardware Options		
	Output 3	Output 4
AA =	None	None
AJ =	None	Mechanical relay 5A, Form A
AK =	None	SSR Form A, 0.5A
CA =	Switched dc/open collector	None
CC =	Switched dc/open collector	Switched dc
CH =	Switched dc/open collector	NO-ARC 15A power control
CJ =	Switched dc/open collector	Mechanical relay 5A, Form A
CK =	Switched dc/open collector	SSR Form A, 0.5A
EA =	Mechanical relay 5A, Form C	None
EC =	Mechanical relay 5A, Form C	Switched dc
EH =	Mechanical relay 5A, Form C	NO-ARC 15A power control
EJ =	Mechanical relay 5A, Form C	Mechanical relay 5A, Form A
EK =	Mechanical relay 5A, Form C	SSR Form A, 0.5A
FA =	Universal process	None
FC =	Universal process	Switched dc
FJ =	Universal process	Mechanical relay 5A, Form A
FK =	Universal process	SSR Form A, 0.5A
KH =	SSR Form A, 0.5A	NO-ARC 15A power control
KK =	SSR Form A, 0.5A	SSR Form A, 0.5A
1/6 DIN Models: If communication options 2 thru 6 is ordered in previous digit, then Option AA must be ordered here.		
1/6 DIN Models: Output options CH, EH and KH are not valid.		

⑫ Additional Options	
A =	Standard
C =	Enhanced firmware which includes compressor control, cascade, ratio, differential, square-root and motorized valve control without feedback.
D =	Standard with isolated input 1, input 2 is always isolated.
F =	Enhanced firmware with isolated input 1, input 2 is always isolated.
Note: Auxiliary control function C or J required for cascade control.	

⑬ ⑭ Custom Options	
AA =	Standard EZ-ZONE PM face plate
12 =	Class 1, Div. 2 (not available with integrated limit Option "L" or "M", or with Output types E, H or J)

Enhanced Limit Model Ordering Information

Universal Sensor Input, Configuration Communications, Red and Green Seven-Segment Displays

Part Number

1 2	3	4	5	6 7	8	9	10 11	12	13 14
	Package Size	Primary Function	Power Supply, Digital I/O	Output 1 and 2 Hardware Options	Add'l Comm. Options	Future Option	Output 3 and 4 Hardware Options	Isolated Input Option	Custom Options
PM					-	A			

3 Package Size	
6 =	1/6 DIN
8 =	1/6 DIN vertical
9 =	1/6 DIN horizontal
4 =	1/4 DIN

4 Primary Function	
L =	Limit controller with universal input
M =	Limit controller with thermistor input
D =	Custom firmware

5 Power Supply, Digital Inputs/Outputs (I/O)	
1 =	100 to 240VAC
2 =	100 to 240VAC plus 2 digital I/O points
3 =	20 to 28VAC or 12 to 40VDC
4 =	20 to 28VAC or 12 to 40VDC, plus 2 digital I/O points

6 7 Output 1 and 2 Hardware Options		
	Output 1	Output 2
AJ =	None	Mechanical relay 5A, Form A
CJ =	Switched dc/open collector	Mechanical relay 5A, Form A
EJ =	Mechanical relay 5A, Form C	Mechanical relay 5A, Form A

8 Additional Communication Options	
Standard bus always included	
A =	None
1 =	EIA 485 Modbus® RTU
2 =	EIA 232/485 Modbus® RTU
3 =	EtherNet/IP™ Modbus® TCP
5 =	DeviceNet™
6 =	PROFIBUS DP

10 11 Output 3 and 4 Hardware Options		
	Output 3	Output 4
AA =	None	None
AJ =	None	Mechanical relay 5A, Form A
AK =	None	SSR Form A, 0.5A
CA =	Switched dc/open collector	None
CC =	Switched dc/open collector	Switched dc
CJ =	Switched dc/open collector	Mechanical relay 5A, Form A
CK =	Switched dc/open collector	SSR Form A, 0.5A
EA =	Mechanical relay 5A, Form C	None
EC =	Mechanical relay 5A, Form C	Switched dc
EJ =	Mechanical relay 5A, Form C	Mechanical relay 5A, Form A
EK =	Mechanical relay 5A, Form C	SSR Form A, 0.5A
FA =	Universal process	None
FC =	Universal process	Switched dc
FJ =	Universal process	Mechanical relay 5A, Form A
FK =	Universal process	SSR Form A, 0.5A
KK =	SSR Form A, 0.5A	SSR Form A, 0.5A

1/6 DIN Models: If communication options 2 thru 6 is ordered in previous digit, then Option AA must be ordered here.

12 Isolated Input Option	
A =	None
D =	Isolated input 1

13 14 Custom Options	
Firmware, overlays, parameter settings	
AA =	Standard EZ-ZONE PM face plate